

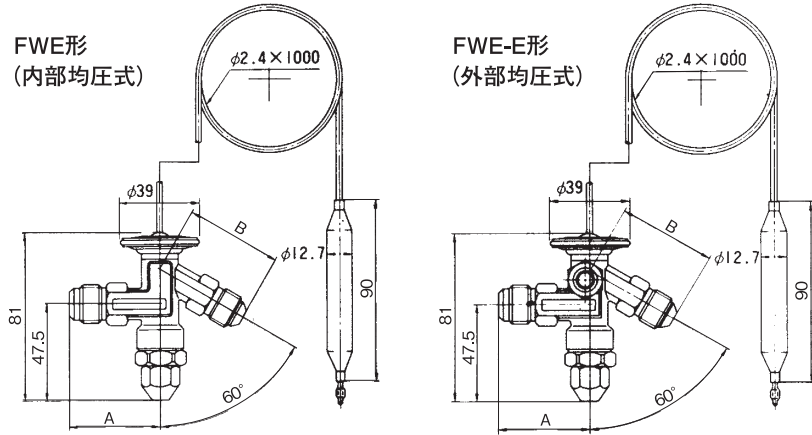

FWE形温度膨張弁

- ホットガスデフロストサイクルにも使用可能なフレア接続方式の温度膨張弁です。また使用目的によって蒸発温度を自由に選択ができます。



用途	冷房・空調・冷蔵・冷凍・環境装置など広範囲に使用できます。 ホットガス デフロストサイクル用としても最適です。			
蒸発温度範囲	記号	ワイドレンジ W	中温 M	低温 L
	R134a	10℃～-30℃	-1℃～-30℃	-18℃～-30℃
	R407C	10℃～-40℃	-1℃～-40℃	-18℃～-40℃
	R404A	10℃～-45℃	-1℃～-45℃	-18℃～-45℃
	R410A	10℃～-45℃	—	—
	R448A R449A R407H	10℃～-45℃	—	—
静止過熱度調節範囲(※)	1～7℃ (通常は調節不要です)			
工場出荷設定値(※)	静止過熱度：3.5～4.5℃			
最高使用圧力	R134a/R407C/R404A/R448A/R449A/R407H:1.47MPaG(低圧側)/2.75MPaG(高圧側) R410A:3.3MPaG			
気密圧力	R134a/R407C/R404A/R448A/R449A/R407H:1.67MPaG(低圧側)/2.95MPaG(高圧側) R410A:3.4MPaG			
耐圧圧力	R134a/R407C/R404A/R448A/R449A/R407H:4.42MPaG R410A:4.5MPaG			
感温筒封入方式	ガスクロスチャージ			
使用最高温度	120℃			
接続方式	フレア式			
質量	410g(内部均圧式)、420g(外部均圧式)			

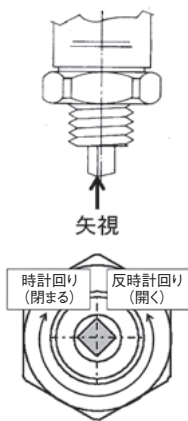

- 配管の気密を確認する際は、膨張弁に気密圧力以上の圧力がかからないよう注意して下さい。
- R410A用をヒートポンプ回路にて使用される場合は、膨張弁の感温筒と外均管を四方弁と圧縮機入り口側アクキュレータの間に取付けて下さい。
(※)R407C用は旧R22用をベースに設定されておりますので、若干カタログ値と異なります。
(※)R448A、R449A、R407H用はR448A、R449Aをベースに設定されております。
工場出荷状態でR407Hを使用される場合、静止過熱度は1.5～2.5℃となります。
3.5～4.5℃で使用するには調節ネジにて調節して下さい。
- 調節ネジは、矢視方向より時計回りが閉まり方向(過熱度増)、反時計回りが開き方向(過熱度減)です。時計回り方向に、調節範囲を超えて回し続けると調節できなくなる場合がありますので注意して下さい。
- 調整後は必ずキャップを戻して下さい。調節ネジ用キャップの締め付けトルクは8～10N・mです。
- 冷媒(R1234yf対応)についてはご相談下さい。

調節ネジ1回転あたりの圧力変化量

R134a	R407C	R404A	R410A	R448A/R449A R407H
約0.015MPa	[0.5トン以上] 約0.015MPa [0.3トン以下] 約0.030MPa	約0.015MPa	[1.0トン以上] 約0.015MPa [0.5トン以下] 約0.015MPa	約0.030MPa

仕 様

形 式		公称 容量 kW	接続配管径 入口×出口mm(インチ)	使用冷媒					寸法 mm		
内部均圧式	外部均圧式			R134a	R407C	R404A	R410A	R448A R449A R407H	A	B	
FWE-124□□	FWE-E 124□□	0.35	6.35(1/4)×12.70(1/2)	/	※	/	/	/	48		
FWE-224□□	FWE-E 224□□	0.7		/	※	/	/	/			
FWE-324□□	FWE-E 324□□	1.1		○	○	○	/	○			
FWE-524□□	FWE-E 524□□	1.8		○	○	○	※	○			
FWE-1024□□	FWE-E 1024□□	3.5		○	○	○	※	○			
FWE-1524□□	FWE-E 1524□□	5.3		○	○	○	※	○			
FWE-134□□	FWE-E 134□□	0.35	9.52(3/8)×12.70(1/2)	/	※	/	/	/	45		
FWE-234□□	FWE-E 234□□	0.7		/	※	/	/	/			
FWE-334□□	FWE-E 334□□	1.1		○	○	○	/	○			
FWE-534□□	FWE-E 534□□	1.8		○	○	○	○	○			
FWE-1034□□	FWE-E 1034□□	3.5		○	○	○	○	○			
FWE-1534□□	FWE-E 1534□□	5.3		○	○	○	○	○			
FWE-2034□□	FWE-E 2034□□	7.0		○	○	○	○	○			
FWE-2534□□	FWE-E 2534□□	8.8		○	○	○	○	○			
FWE-3034□□	FWE-E 3034□□	10.6		○	○	○	○	○			
FWE-4034□□	FWE-E 4034□□	14.1		/	○	/	○	○			
FWE-5034□□	FWE-E 5034□□	17.6		/	○	/	/	○			
FWE-2045□□	FWE-E 2045□□	7.0		○	/	○	/	○	47		49
FWE-2545□□	FWE-E 2545□□	8.8		○	/	○	/	○			
FWE-3045□□	FWE-E 3045□□	10.6		○	○	○	/	○			
FWE-4045□□	FWE-E 4045□□	14.1	/	○	/	/	○				
FWE-5045□□	FWE-E 5045□□	17.6	/	○	/	/	○				

※：受注生産

形式と記号

Fシリーズの各膨張弁の形式は、次の表示がされています。

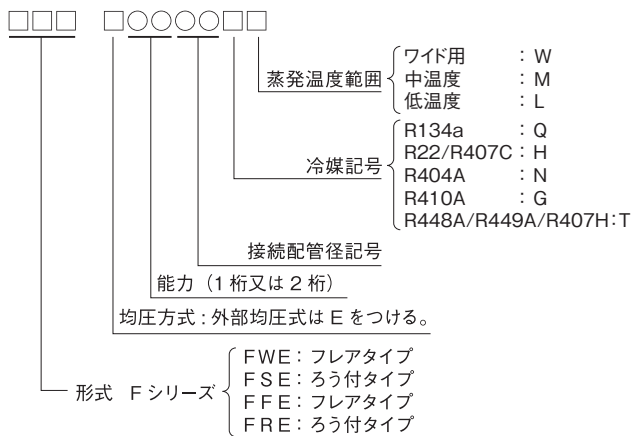

FWE形・FSE形用防滴カバー

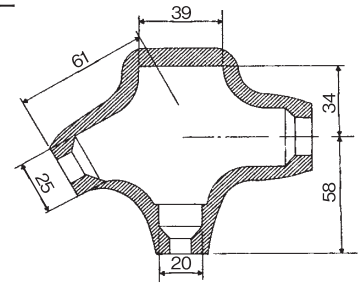

本体を両サイドからはさんでテープで止めて下さい。
 コールテープで覆うと、より完全にシールができます。
 材質：ポリエチレンフォーム

<容量変化表> R134a用 FWE形・FSE形・FFE形・FRE形 (代表：ワイドレンジ)

条件：凝縮温度別、過冷却度：0℃、過熱度変化：4℃時の容量 [kW]

配管やエバポレータなどの圧力損失を0とした時のものです。

製品名		凝縮温度 (°C)						
		30	35	38	40	45	50	
F□E-3□□QW F□E-E3□□QW	蒸発温度 (°C)	10	1.20	1.31	1.36	1.39	1.46	1.50
		5	1.13	1.21	1.24	1.27	1.31	1.34
		0	1.05	1.11	1.14	1.16	1.19	1.20
		-5	0.95	0.99	1.01	1.02	1.04	1.05
		-10	0.85	0.88	0.90	0.90	0.92	0.92
		-15	0.75	0.77	0.78	0.78	0.79	0.79
		-20	0.64	0.66	0.66	0.67	0.67	0.67
		-25	0.54	0.55	0.56	0.56	0.56	0.56
		-30	0.48	0.49	0.49	0.49	0.49	0.48
製品名		凝縮温度 (°C)						
		30	35	38	40	45	50	
F□E-5□□QW F□E-E5□□QW	蒸発温度 (°C)	10	1.98	2.16	2.24	2.30	2.40	2.47
		5	1.87	1.99	2.06	2.10	2.17	2.21
		0	1.72	1.81	1.86	1.89	1.94	1.96
		-5	1.66	1.73	1.77	1.79	1.82	1.84
		-10	1.38	1.43	1.45	1.47	1.49	1.49
		-15	1.18	1.22	1.23	1.24	1.25	1.25
		-20	1.02	1.05	1.06	1.06	1.07	1.06
		-25	0.89	0.91	0.92	0.92	0.92	0.92
		-30	0.75	0.76	0.77	0.77	0.77	0.76
製品名		凝縮温度 (°C)						
		30	35	38	40	45	50	
F□E-10□□QW F□E-E10□□QW	蒸発温度 (°C)	10	3.95	4.31	4.49	4.59	4.80	4.94
		5	3.73	3.99	4.12	4.19	4.34	4.43
		0	3.43	3.62	3.71	3.76	3.86	3.91
		-5	3.33	3.48	3.55	3.59	3.66	3.69
		-10	2.75	2.85	2.90	2.92	2.96	2.97
		-15	2.40	2.47	2.50	2.52	2.54	2.54
		-20	2.07	2.12	2.14	2.15	2.16	2.15
		-25	1.79	1.82	1.84	1.84	1.85	1.83
		-30	1.54	1.56	1.57	1.57	1.57	1.55
製品名		凝縮温度 (°C)						
		30	35	38	40	45	50	
F□E-15□□QW F□E-E15□□QW	蒸発温度 (°C)	10	5.93	6.47	6.73	6.89	7.20	7.41
		5	5.63	6.02	6.21	6.32	6.54	6.68
		0	5.22	5.50	5.64	5.72	5.87	5.95
		-5	4.69	4.89	4.99	5.04	5.14	5.19
		-10	4.17	4.32	4.38	4.42	4.48	4.50
		-15	3.64	3.74	3.79	3.82	3.85	3.85
		-20	3.13	3.20	3.23	3.25	3.27	3.25
		-25	2.72	2.77	2.79	2.80	2.80	2.78
		-30	2.35	2.38	2.40	2.40	2.40	2.37

製品名		凝縮温度 (°C)						
		30	35	38	40	45	50	
F□E-20□□QW F□E-E20□□QW	蒸発温度 (°C)	10	8.14	8.88	9.24	9.46	9.89	10.2
		5	7.70	8.24	8.50	8.65	8.95	9.14
		0	7.14	7.53	7.72	7.83	8.03	8.15
		-5	6.37	6.65	6.78	6.85	6.99	7.05
		-10	5.77	5.97	6.07	6.12	6.21	6.23
		-15	5.00	5.14	5.21	5.24	5.29	5.29
		-20	4.28	4.39	4.43	4.45	4.48	4.46
		-25	3.76	3.83	3.86	3.87	3.88	3.85
		-30	3.23	3.28	3.30	3.31	3.30	3.27
製品名		凝縮温度 (°C)						
		30	35	38	40	45	50	
F□E-25□□QW F□E-E25□□QW	蒸発温度 (°C)	10	9.71	10.6	11.0	11.3	11.8	12.2
		5	9.18	9.82	10.1	10.3	10.7	10.9
		0	8.56	9.03	9.26	9.39	9.63	9.77
		-5	7.69	8.03	8.19	8.28	8.44	8.51
		-10	6.86	7.11	7.22	7.28	7.38	7.41
		-15	6.05	6.22	6.30	6.34	6.40	6.40
		-20	5.20	5.32	5.37	5.40	5.43	5.40
		-25	4.53	4.62	4.65	4.67	4.67	4.64
		-30	3.91	3.98	4.00	4.01	4.00	3.96
製品名		凝縮温度 (°C)						
		30	35	38	40	45	50	
F□E-30□□QW F□E-E30□□QW	蒸発温度 (°C)	10	10.8	11.8	12.2	12.5	13.1	13.5
		5	10.2	10.9	11.2	11.5	11.8	12.1
		0	9.48	9.99	10.2	10.4	10.7	10.8
		-5	8.51	8.88	9.06	9.16	9.34	9.42
		-10	7.60	7.87	8.00	8.07	8.18	8.21
		-15	6.67	6.87	6.95	7.00	7.06	7.06
		-20	5.78	5.92	5.98	6.01	6.04	6.01
		-25	5.07	5.17	5.21	5.23	5.24	5.20
		-30	4.38	4.45	4.48	4.49	4.48	4.43

<容量変化表> R407C用 FWE形・FSE形・FFE形・FRE形 (代表:ワイドレンジ)

条件：凝縮温度別、過冷却度：0℃、過熱度変化：3.5℃時の容量 [kW]

配管やエバポレータなどの圧力損失を0とした時のものです。

製品名		凝縮温度 (°C)					
		30	35	38	40	45	50
F□E-3□□HW F□E-E3□□HW	10	1.09	1.13	1.18	1.20	1.20	1.25
	5	1.04	1.07	1.11	1.12	1.12	1.15
	0	0.98	1.00	1.04	1.04	1.03	1.06
	-5	0.94	0.94	0.97	0.98	0.96	0.98
	-10	0.84	0.84	0.87	0.87	0.85	0.87
	-15	0.77	0.76	0.79	0.79	0.77	0.78
	-20	0.69	0.69	0.71	0.71	0.69	0.69
	-25	0.60	0.59	0.61	0.60	0.59	0.59
	-30	0.54	0.53	0.54	0.54	0.52	0.53
	-35	0.45	0.45	0.46	0.45	0.44	0.44
	-40	0.39	0.39	0.39	0.39	0.38	0.38
製品名		凝縮温度 (°C)					
		30	35	38	40	45	50
F□E-5□□HW F□E-E5□□HW	10	2.07	2.15	2.25	2.28	2.29	2.37
	5	2.03	2.08	2.16	2.19	2.17	2.24
	0	1.91	1.94	2.01	2.02	2.00	2.05
	-5	1.84	1.85	1.91	1.92	1.89	1.93
	-10	1.67	1.67	1.72	1.73	1.69	1.72
	-15	1.51	1.50	1.55	1.55	1.51	1.53
	-20	1.39	1.38	1.41	1.41	1.37	1.39
	-25	1.21	1.19	1.22	1.22	1.18	1.19
	-30	1.08	1.06	1.08	1.08	1.04	1.05
	-35	0.88	0.87	0.89	0.89	0.85	0.86
	-40	0.79	0.77	0.79	0.79	0.75	0.76
製品名		凝縮温度 (°C)					
		30	35	38	40	45	50
F□E-10□□HW F□E-E10□□HW	10	3.40	3.53	3.70	3.76	3.77	3.90
	5	3.33	3.41	3.55	3.59	3.57	3.68
	0	3.12	3.16	3.28	3.31	3.27	3.35
	-5	3.00	3.02	3.12	3.14	3.08	3.15
	-10	2.71	2.71	2.79	2.80	2.74	2.79
	-15	2.43	2.42	2.49	2.49	2.43	2.46
	-20	2.25	2.23	2.29	2.29	2.22	2.25
	-25	1.95	1.92	1.97	1.97	1.91	1.92
	-30	1.73	1.70	1.74	1.74	1.68	1.69
	-35	1.42	1.39	1.42	1.42	1.37	1.37
	-40	1.26	1.24	1.26	1.26	1.21	1.21

製品名		凝縮温度 (°C)					
		30	35	38	40	45	50
F□E-15□□HW F□E-E15□□HW	10	6.83	7.09	7.43	7.54	7.56	7.83
	5	6.68	6.85	7.13	7.21	7.17	7.39
	0	6.26	6.35	6.59	6.64	6.56	6.72
	-5	6.02	6.06	6.26	6.30	6.19	6.32
	-10	5.44	5.45	5.61	5.63	5.51	5.60
	-15	4.90	4.88	5.01	5.02	4.90	4.96
	-20	4.51	4.47	4.58	4.59	4.46	4.51
	-25	3.93	3.88	3.98	3.97	3.85	3.88
	-30	3.49	3.44	3.52	3.51	3.39	3.41
	-35	2.88	2.82	2.88	2.88	2.77	2.78
	-40	2.55	2.50	2.55	2.54	2.44	2.44
製品名		凝縮温度 (°C)					
		30	35	38	40	45	50
F□E-20□□HW F□E-E20□□HW	10	8.27	8.59	9.00	9.13	9.16	9.48
	5	8.12	8.32	8.66	8.75	8.71	8.97
	0	7.65	7.76	8.05	8.11	8.02	8.21
	-5	7.34	7.38	7.63	7.67	7.55	7.70
	-10	6.59	6.59	6.79	6.82	6.68	6.79
	-15	5.96	5.93	6.10	6.11	5.96	6.04
	-20	5.48	5.44	5.58	5.58	5.42	5.48
	-25	4.76	4.70	4.82	4.82	4.66	4.70
	-30	4.23	4.16	4.26	4.25	4.11	4.13
	-35	3.47	3.41	3.48	3.47	3.34	3.35
	-40	3.08	3.02	3.08	3.07	2.95	2.95
製品名		凝縮温度 (°C)					
		30	35	38	40	45	50
F□E-25□□HW F□E-E25□□HW	10	10.4	10.8	11.3	11.4	11.5	11.9
	5	10.1	10.4	10.8	10.9	10.9	11.2
	0	9.54	9.67	10.0	10.1	9.99	10.2
	-5	9.15	9.21	9.52	9.57	9.41	9.60
	-10	8.27	8.27	8.53	8.55	8.38	8.52
	-15	7.46	7.43	7.63	7.65	7.46	7.56
	-20	6.87	6.81	6.99	6.99	6.80	6.87
	-25	5.97	5.90	6.04	6.04	5.85	5.90
	-30	5.27	5.19	5.31	5.30	5.12	5.15
	-35	4.37	4.28	4.38	4.37	4.20	4.22
	-40	3.88	3.80	3.88	3.87	3.71	3.72

<容量変化表> R407C用 FWE形・FSE形・FFE形・FRE形 (代表:ワイドレンジ)

条件：凝縮温度別、過冷却度：0℃、過熱度変化：3.5℃時の容量 [kW]

配管やエバポレータなどの圧力損失を0とした時のものです。

製品名		凝縮温度 (°C)					
		30	35	38	40	45	50
F□E-30□□HW F□E-E30□□HW	10	14.2	14.8	15.5	15.7	15.8	16.3
	5	13.9	14.3	14.9	15.0	15.0	15.4
	0	13.0	13.22	13.71	13.81	13.66	13.99
	-5	12.6	12.7	13.1	13.2	12.9	13.2
	-10	11.4	11.4	11.7	11.8	11.5	11.7
	-15	10.3	10.3	10.5	10.6	10.3	10.4
	-20	9.47	9.39	9.64	9.64	9.37	9.47
	-25	8.22	8.12	8.32	8.31	8.05	8.12
	-30	7.34	7.23	7.39	7.38	7.13	7.17
	-35	6.03	5.92	6.05	6.03	5.81	5.83
	-40	5.38	5.27	5.38	5.36	5.14	5.15
製品名		凝縮温度 (°C)					
		30	35	38	40	45	50
F□E-40□□HW F□E-E40□□HW	10	17.0	17.8	18.5	18.8	18.8	19.5
	5	16.6	17.0	17.8	17.9	17.8	18.4
	0	15.7	15.9	16.5	16.6	16.4	16.9
	-5	15.1	15.2	15.7	15.8	15.5	15.8
	-10	13.6	13.6	14.0	14.1	13.8	14.0
	-15	12.4	12.4	12.7	12.7	12.4	12.6
	-20	11.4	11.3	11.6	11.6	11.3	11.4
	-25	10.0	9.89	10.1	10.1	9.81	9.89
	-30	8.88	8.74	8.95	8.93	8.62	8.68
	-35	7.38	7.24	7.40	7.38	7.11	7.14
	-40	6.55	6.41	6.55	6.52	6.26	6.28

製品名		凝縮温度 (°C)					
		30	35	38	40	45	50
F□E-50□□HW F□E-E50□□HW	10	18.8	19.5	20.5	20.8	20.8	21.6
	5	18.4	18.8	19.6	19.8	19.7	20.3
	0	17.4	17.6	18.3	18.4	18.2	18.6
	-5	16.7	16.8	17.4	17.5	17.2	17.6
	-10	15.2	15.2	15.6	15.7	15.4	15.6
	-15	13.8	13.7	14.1	14.1	13.8	13.9
	-20	12.7	12.6	12.9	12.9	12.6	12.7
	-25	11.1	10.9	11.2	11.2	10.9	10.9
	-30	9.86	9.71	9.94	9.92	9.58	9.64
	-35	8.16	8.01	8.19	8.16	7.86	7.89
	-40	7.27	7.12	7.27	7.24	6.95	6.96

容量変化表：R404A用 FWE形・FSE形・FFE形・FRE形 (代表:ワイドレンジ)

<容量変化表> R404A用 FWE形・FSE形・FFE形・FRE形 (代表:ワイドレンジ)

条件：凝縮温度別、過冷却度：0℃、過熱度変化：3.5℃時の容量 [kW]

配管やエバポレータなどの圧力損失を0とした時のものです。

製品名		凝縮温度 (°C)						
		30	35	38	40	45	50	
F□E-3□□NW F□E-E3□□NW	蒸発温度 (°C)	10	1.52	1.62	1.65	1.67	1.69	1.66
		5	1.48	1.55	1.56	1.57	1.56	1.52
		0	1.45	1.50	1.50	1.49	1.49	1.44
		-5	1.35	1.38	1.37	1.36	1.35	1.29
		-10	1.25	1.27	1.26	1.25	1.22	1.17
		-15	1.10	1.11	1.09	1.08	1.05	1.00
		-20	0.98	0.98	0.97	0.96	0.92	0.87
		-25	0.86	0.85	0.84	0.83	0.80	0.75
		-30	0.78	0.77	0.76	0.75	0.71	0.67
		-35	0.67	0.65	0.64	0.63	0.60	0.56
		-40	0.51	0.50	0.49	0.48	0.45	0.42
		-45	0.42	0.41	0.40	0.39	0.37	0.34
製品名		凝縮温度 (°C)						
		30	35	38	40	45	50	
F□E-5□□NW F□E-E5□□NW	蒸発温度 (°C)	10	2.50	2.67	2.71	2.74	2.77	2.72
		5	2.43	2.54	2.56	2.57	2.56	2.50
		0	2.38	2.45	2.45	2.44	2.43	2.35
		-5	2.21	2.25	2.24	2.23	2.20	2.11
		-10	2.04	2.06	2.05	2.04	1.99	1.90
		-15	1.77	1.78	1.76	1.74	1.69	1.61
		-20	1.57	1.57	1.55	1.53	1.48	1.40
		-25	1.38	1.37	1.35	1.33	1.28	1.20
		-30	1.27	1.26	1.23	1.22	1.16	1.09
		-35	1.06	1.05	1.02	1.01	0.96	0.89
		-40	0.80	0.79	0.77	0.75	0.72	0.66
		-45	0.66	0.65	0.63	0.62	0.58	0.53
製品名		凝縮温度 (°C)						
		30	35	38	40	45	50	
F□E-10□□NW F□E-E10□□NW	蒸発温度 (°C)	10	5.04	5.39	5.48	5.53	5.59	5.50
		5	4.89	5.11	5.15	5.18	5.16	5.04
		0	4.77	4.91	4.92	4.91	4.88	4.72
		-5	4.43	4.52	4.50	4.49	4.41	4.24
		-10	4.09	4.14	4.10	4.08	3.99	3.81
		-15	3.55	3.56	3.52	3.50	3.40	3.22
		-20	3.19	3.19	3.14	3.11	3.00	2.84
		-25	2.78	2.76	2.71	2.68	2.57	2.42
		-30	2.56	2.53	2.48	2.44	2.34	2.18
		-35	2.15	2.12	2.07	2.04	1.94	1.80
		-40	1.64	1.61	1.57	1.54	1.46	1.35
		-45	1.32	1.29	1.26	1.23	1.16	1.07
製品名		凝縮温度 (°C)						
		30	35	38	40	45	50	
F□E-15□□NW F□E-E15□□NW	蒸発温度 (°C)	10	7.64	8.16	8.29	8.37	8.46	8.32
		5	7.44	7.77	7.84	7.88	7.86	7.66
		0	7.28	7.50	7.51	7.50	7.45	7.20
		-5	6.71	6.84	6.81	6.79	6.68	6.42
		-10	6.21	6.28	6.23	6.20	6.06	5.78
		-15	5.39	5.41	5.35	5.31	5.16	4.89
		-20	4.82	4.82	4.74	4.70	4.54	4.29
		-25	4.23	4.20	4.13	4.08	3.92	3.69
		-30	3.89	3.84	3.77	3.71	3.56	3.32
		-35	3.27	3.21	3.14	3.09	2.94	2.74
		-40	2.50	2.44	2.38	2.34	2.22	2.05
		-45	2.02	1.97	1.92	1.88	1.78	1.63

製品名		凝縮温度 (°C)						
		30	35	38	40	45	50	
F□E-20□□NW F□E-E20□□NW	蒸発温度 (°C)	10	10.4	11.1	11.3	11.4	11.6	11.4
		5	10.2	10.6	10.7	10.8	10.7	10.5
		0	9.90	10.2	10.2	10.2	10.1	9.80
		-5	9.20	9.37	9.34	9.31	9.16	8.80
		-10	8.51	8.60	8.53	8.49	8.30	7.92
		-15	7.43	7.45	7.37	7.31	7.11	6.75
		-20	6.63	6.62	6.52	6.46	6.24	5.90
		-25	5.84	5.79	5.70	5.63	5.41	5.09
		-30	5.41	5.34	5.23	5.16	4.94	4.62
		-35	4.51	4.44	4.34	4.27	4.07	3.78
		-40	3.45	3.37	3.29	3.23	3.07	2.83
		-45	2.79	2.73	2.65	2.60	2.45	2.26
製品名		凝縮温度 (°C)						
		30	35	38	40	45	50	
F□E-25□□NW F□E-E25□□NW	蒸発温度 (°C)	10	12.5	13.3	13.6	13.7	13.8	13.6
		5	12.1	12.7	12.8	12.9	12.8	12.5
		0	11.9	12.2	12.2	12.2	12.2	11.7
		-5	11.1	11.3	11.2	11.2	11.0	10.6
		-10	10.2	10.3	10.2	10.2	9.96	9.51
		-15	8.99	9.02	8.92	8.85	8.60	8.16
		-20	8.04	8.03	7.91	7.83	7.57	7.15
		-25	7.07	7.01	6.90	6.81	6.55	6.16
		-30	6.50	6.42	6.29	6.20	5.94	5.55
		-35	5.49	5.40	5.28	5.20	4.95	4.60
		-40	4.21	4.12	4.02	3.95	3.75	3.46
		-45	3.39	3.31	3.22	3.16	2.98	2.74
製品名		凝縮温度 (°C)						
		30	35	38	40	45	50	
F□E-30□□NW F□E-E30□□NW	蒸発温度 (°C)	10	13.8	14.8	15.0	15.2	15.3	15.1
		5	13.4	14.1	14.2	14.2	14.2	13.9
		0	13.1	13.5	13.5	13.5	13.4	12.9
		-5	12.2	12.4	12.4	12.4	12.2	11.7
		-10	11.3	11.4	11.3	11.3	11.0	10.5
		-15	9.92	9.95	9.84	9.76	9.48	9.00
		-20	8.92	8.90	8.77	8.68	8.39	7.93
		-25	7.88	7.82	7.69	7.59	7.30	6.86
		-30	7.24	7.15	7.01	6.91	6.62	6.18
		-35	6.09	6.00	5.86	5.77	5.50	5.11
		-40	4.69	4.59	4.48	4.40	4.17	3.85
		-45	3.80	3.71	3.60	3.54	3.34	3.07

容量変化表：R410A用 FWE形・FSE形・FFE形・FRE形 (ワイドレンジ)

<容量変化表> R410A用 FWE形・FSE形・FFE形・FRE形 (ワイドレンジ)

条件：凝縮温度別、過冷却度：0℃、過熱度変化：3.5℃時の容量 [kW]

配管やエバポレータなどの圧力損失を0とした時のものです。

製品名		凝縮温度 (°C)						
		30	35	38	40	45	50	
F□E-5□□GW F□E-E5□□GW	蒸発温度 (°C)	10	2.62	2.83	2.90	2.94	3.04	3.02
		5	2.44	2.59	2.63	2.66	2.72	2.68
		0	2.44	2.56	2.58	2.60	2.63	2.58
		-5	2.46	2.55	2.56	2.57	2.59	2.53
		-10	2.37	2.44	2.44	2.44	2.45	2.38
		-15	2.23	2.28	2.27	2.27	2.27	2.19
		-20	2.02	2.05	2.04	2.04	2.03	1.95
		-25	1.90	1.93	1.91	1.90	1.89	1.81
		-30	1.60	1.62	1.60	1.59	1.58	1.51
		-35	1.48	1.49	1.47	1.46	1.44	1.38
		-40	1.38	1.39	1.37	1.36	1.34	1.28
		-45	1.11	1.12	1.10	1.09	1.07	1.02
製品名		凝縮温度 (°C)						
F□E-10□□GW F□E-E10□□GW	蒸発温度 (°C)	10	3.39	3.66	3.75	3.81	3.93	3.91
		5	3.16	3.35	3.40	3.44	3.51	3.46
		0	3.02	3.16	3.19	3.21	3.26	3.19
		-5	3.03	3.14	3.15	3.16	3.19	3.11
		-10	2.95	3.03	3.03	3.03	3.04	2.95
		-15	2.83	2.89	2.88	2.88	2.88	2.78
		-20	2.51	2.56	2.54	2.54	2.52	2.43
		-25	2.36	2.39	2.37	2.36	2.34	2.25
		-30	1.95	1.97	1.95	1.94	1.92	1.84
		-35	1.82	1.83	1.81	1.80	1.78	1.70
		-40	1.66	1.67	1.65	1.64	1.62	1.54
		-45	1.29	1.29	1.27	1.26	1.24	1.18
製品名		凝縮温度 (°C)						
F□E-15□□GW F□E-E15□□GW	蒸発温度 (°C)	10	5.52	5.97	6.11	6.20	6.40	6.36
		5	5.11	5.42	5.50	5.56	5.68	5.60
		0	4.69	4.91	4.95	4.98	5.05	4.95
		-5	4.64	4.81	4.83	4.85	4.89	4.76
		-10	4.58	4.71	4.71	4.72	4.73	4.59
		-15	4.27	4.37	4.35	4.35	4.34	4.20
		-20	3.70	3.77	3.74	3.73	3.72	3.58
		-25	3.41	3.46	3.43	3.42	3.39	3.26
		-30	2.83	2.86	2.83	2.82	2.79	2.67
		-35	2.55	2.57	2.54	2.53	2.49	2.38
		-40	2.37	2.38	2.35	2.33	2.30	2.19
		-45	1.80	1.81	1.78	1.77	1.74	1.65
製品名		凝縮温度 (°C)						
F□E-20□□GW F□E-E20□□GW	蒸発温度 (°C)	10	8.95	9.68	9.91	10.1	10.4	10.3
		5	8.17	8.67	8.80	8.89	9.09	8.96
		0	7.56	7.92	7.98	8.03	8.15	7.98
		-5	7.55	7.83	7.85	7.88	7.94	7.74
		-10	7.43	7.65	7.64	7.65	7.68	7.45
		-15	6.98	7.14	7.11	7.11	7.10	6.86
		-20	6.17	6.28	6.24	6.23	6.20	5.97
		-25	5.68	5.76	5.71	5.69	5.65	5.42
		-30	4.83	4.88	4.83	4.81	4.76	4.56
		-35	4.41	4.45	4.39	4.37	4.31	4.11
		-40	4.27	4.29	4.23	4.20	4.14	3.94
		-45	3.28	3.29	3.24	3.22	3.16	3.00

製品名		凝縮温度 (°C)						
		30	35	38	40	45	50	
F□E-25□□GW F□E-E25□□GW	蒸発温度 (°C)	10	9.54	10.3	10.6	10.7	11.1	11.0
		5	8.93	9.47	9.61	9.71	9.92	9.78
		0	8.42	8.81	8.88	8.94	9.07	8.89
		-5	8.42	8.73	8.76	8.79	8.86	8.64
		-10	8.37	8.62	8.61	8.62	8.65	8.39
		-15	7.90	8.08	8.05	8.05	8.04	7.77
		-20	7.02	7.15	7.10	7.09	7.06	6.79
		-25	6.60	6.69	6.63	6.61	6.56	6.30
		-30	5.57	5.63	5.57	5.55	5.49	5.25
		-35	5.09	5.14	5.07	5.04	4.98	4.75
		-40	4.83	4.86	4.79	4.76	4.69	4.46
		-45	3.84	3.85	3.79	3.76	3.70	3.51
製品名		凝縮温度 (°C)						
F□E-30□□GW F□E-E30□□GW	蒸発温度 (°C)	10	12.3	13.3	13.6	13.8	14.2	14.1
		5	10.9	11.5	11.7	11.8	12.1	11.9
		0	10.0	10.4	10.5	10.6	10.7	10.5
		-5	9.85	10.2	10.2	10.3	10.4	10.1
		-10	9.59	9.87	9.86	9.88	9.91	9.61
		-15	8.81	9.02	8.98	8.98	8.97	8.67
		-20	7.59	7.73	7.68	7.67	7.63	7.35
		-25	7.02	7.12	7.06	7.04	6.98	6.70
		-30	5.85	5.92	5.85	5.82	5.77	5.52
		-35	5.29	5.34	5.27	5.24	5.18	4.94
		-40	4.91	4.94	4.87	4.84	4.77	4.54
		-45	3.92	3.93	3.87	3.84	3.78	3.58
製品名		凝縮温度 (°C)						
F□E-40□□GW F□E-E40□□GW	蒸発温度 (°C)	10	15.0	16.3	16.7	16.9	17.5	17.3
		5	14.3	15.2	15.4	15.6	15.9	15.7
		0	13.6	14.3	14.4	14.5	14.7	14.4
		-5	13.6	14.1	14.2	14.2	14.4	14.0
		-10	13.7	14.1	14.0	14.1	14.1	13.7
		-15	12.8	13.1	13.1	13.1	13.1	12.6
		-20	11.6	11.8	11.7	11.7	11.7	11.2
		-25	10.9	11.1	11.0	10.9	10.9	10.4
		-30	9.16	9.26	9.16	9.12	9.03	8.64
		-35	8.35	8.42	8.31	8.26	8.16	7.79
		-40	7.87	7.91	7.80	7.75	7.64	7.27
		-45	6.23	6.25	6.15	6.10	6.00	5.70

容量変化表：R448A用 FWE形・FSE形・FFE形・FRE形 (ワイドレンジ)

<容量変化表> R448A FWE形・FSE形・FFE形・FRE形 (ワイドレンジ)

条件：凝縮温度別、過冷却度：0℃、過熱度変化：3.5℃時の容量[kW] / 配管やエバポレータなどの圧力損失を0とした時のものです。

製品名		凝縮温度(℃)						
		30	35	38	40	45	50	
F□E-3□□TW F□E-E3□□TW	蒸発温度(℃)	10	1.04	1.09	1.12	1.13	1.15	1.16
		5	1.00	1.04	1.06	1.07	1.08	1.07
		0	0.94	0.97	0.98	0.99	0.99	0.98
		-5	0.88	0.90	0.91	0.91	0.91	0.90
		-10	0.82	0.83	0.83	0.84	0.83	0.82
		-15	0.74	0.75	0.75	0.75	0.74	0.72
		-20	0.65	0.66	0.66	0.66	0.65	0.63
		-25	0.58	0.58	0.58	0.57	0.56	0.55
		-30	0.51	0.51	0.51	0.50	0.49	0.48
		-35	0.44	0.44	0.44	0.44	0.43	0.41
		-40	0.37	0.36	0.36	0.36	0.35	0.34
-45	0.29	0.28	0.28	0.28	0.27	0.26		
製品名		凝縮温度(℃)						
		30	35	38	40	45	50	
F□E-5□□TW F□E-E5□□TW	蒸発温度(℃)	10	1.98	2.09	2.13	2.16	2.20	2.21
		5	1.94	2.02	2.05	2.07	2.09	2.08
		0	1.83	1.89	1.91	1.92	1.93	1.91
		-5	1.73	1.77	1.78	1.78	1.78	1.76
		-10	1.61	1.64	1.65	1.65	1.64	1.61
		-15	1.47	1.48	1.49	1.48	1.47	1.44
		-20	1.30	1.31	1.30	1.30	1.28	1.25
		-25	1.14	1.14	1.14	1.14	1.12	1.09
		-30	1.01	1.01	1.00	1.00	0.98	0.95
		-35	0.88	0.88	0.87	0.87	0.85	0.82
		-40	0.74	0.73	0.73	0.72	0.70	0.68
-45	0.63	0.63	0.62	0.62	0.60	0.57		
製品名		凝縮温度(℃)						
		30	35	38	40	45	50	
F□E-10□□TW F□E-E10□□TW	蒸発温度(℃)	10	3.25	3.43	3.51	3.55	3.62	3.63
		5	3.19	3.32	3.37	3.40	3.44	3.42
		0	3.00	3.09	3.13	3.14	3.16	3.13
		-5	2.81	2.87	2.90	2.91	2.90	2.86
		-10	2.61	2.66	2.67	2.67	2.65	2.61
		-15	2.37	2.40	2.40	2.40	2.38	2.32
		-20	2.09	2.11	2.11	2.10	2.07	2.02
		-25	1.84	1.84	1.84	1.83	1.80	1.75
		-30	1.62	1.62	1.61	1.61	1.58	1.53
		-35	1.41	1.41	1.40	1.39	1.36	1.31
		-40	1.17	1.17	1.16	1.15	1.12	1.08
-45	0.98	0.97	0.96	0.95	0.92	0.89		
製品名		凝縮温度(℃)						
		30	35	38	40	45	50	
F□E-15□□TW F□E-E15□□TW	蒸発温度(℃)	10	6.53	6.89	7.05	7.13	7.27	7.29
		5	6.40	6.66	6.77	6.83	6.90	6.87
		0	6.03	6.21	6.28	6.32	6.34	6.28
		-5	5.65	5.78	5.82	5.84	5.83	5.75
		-10	5.25	5.33	5.36	5.36	5.33	5.23
		-15	4.76	4.81	4.82	4.82	4.77	4.67
		-20	4.21	4.24	4.24	4.23	4.17	4.07
		-25	3.71	3.72	3.71	3.69	3.63	3.53
		-30	3.28	3.28	3.26	3.25	3.18	3.08
		-35	2.86	2.85	2.83	2.82	2.75	2.66
		-40	2.37	2.36	2.34	2.33	2.27	2.18
-45	1.94	1.93	1.91	1.89	1.84	1.76		
製品名		凝縮温度(℃)						
		30	35	38	40	45	50	
F□E-20□□TW F□E-E20□□TW	蒸発温度(℃)	10	7.90	8.34	8.53	8.64	8.80	8.82
		5	7.79	8.11	8.24	8.31	8.40	8.37
		0	7.34	7.57	7.65	7.69	7.73	7.65
		-5	6.88	7.03	7.09	7.11	7.10	7.00
		-10	6.38	6.49	6.51	6.52	6.48	6.37
		-15	5.78	5.85	5.86	5.85	5.80	5.67
		-20	5.11	5.15	5.14	5.13	5.06	4.94
		-25	4.49	4.51	4.50	4.48	4.41	4.28
		-30	3.97	3.97	3.95	3.94	3.86	3.74
		-35	3.46	3.45	3.43	3.41	3.33	3.22
		-40	2.86	2.85	2.83	2.81	2.74	2.64
-45	2.33	2.31	2.29	2.27	2.20	2.11		

製品名		凝縮温度(℃)						
		30	35	38	40	45	50	
F□E-25□□TW F□E-E25□□TW	蒸発温度(℃)	10	9.91	10.5	10.7	10.8	11.0	11.1
		5	9.70	10.1	10.3	10.4	10.5	10.4
		0	9.15	9.43	9.54	9.59	9.63	9.54
		-5	8.59	8.79	8.86	8.88	8.87	8.75
		-10	7.99	8.12	8.16	8.17	8.12	7.97
		-15	7.25	7.33	7.34	7.34	7.27	7.11
		-20	6.40	6.45	6.44	6.43	6.34	6.18
		-25	5.62	5.64	5.63	5.61	5.52	5.36
		-30	4.97	4.97	4.95	4.92	4.83	4.68
		-35	4.33	4.32	4.29	4.27	4.17	4.03
		-40	3.61	3.59	3.57	3.54	3.45	3.32
-45	3.02	3.00	2.97	2.94	2.86	2.74		
製品名		凝縮温度(℃)						
		30	35	38	40	45	50	
F□E-30□□TW F□E-E30□□TW	蒸発温度(℃)	10	13.6	14.4	14.7	14.9	15.1	15.2
		5	13.3	13.9	14.1	14.2	14.4	14.3
		0	12.5	12.9	13.1	13.2	13.2	13.1
		-5	11.8	12.0	12.1	12.2	12.2	12.0
		-10	11.0	11.2	11.2	11.2	11.2	11.0
		-15	9.99	10.1	10.1	10.1	10.0	9.8
		-20	8.85	8.91	8.90	8.88	8.77	8.54
		-25	7.78	7.80	7.78	7.76	7.63	7.41
		-30	6.87	6.87	6.84	6.81	6.68	6.47
		-35	5.99	5.98	5.94	5.90	5.77	5.57
		-40	5.01	4.99	4.95	4.92	4.79	4.61
-45	4.26	4.24	4.20	4.17	4.07	3.92		
製品名		凝縮温度(℃)						
		30	35	38	40	45	50	
F□E-40□□TW F□E-E40□□TW	蒸発温度(℃)	10	16.3	17.2	17.6	17.8	18.1	18.2
		5	16.0	16.6	16.9	17.0	17.2	17.1
		0	15.0	15.5	15.7	15.8	15.8	15.7
		-5	14.1	14.5	14.6	14.6	14.6	14.4
		-10	13.2	13.4	13.5	13.5	13.4	13.2
		-15	12.0	12.1	12.2	12.2	12.0	11.8
		-20	10.7	10.8	10.7	10.7	10.6	10.3
		-25	9.43	9.46	9.44	9.40	9.25	8.99
		-30	8.37	8.37	8.33	8.29	8.13	7.88
		-35	7.32	7.30	7.25	7.21	7.05	6.81
		-40	6.10	6.07	6.02	5.98	5.83	5.62
-45	4.97	4.94	4.91	4.87	4.75	4.57		
製品名		凝縮温度(℃)						
		30	35	38	40	45	50	
F□E-50□□TW F□E-E50□□TW	蒸発温度(℃)	10	18.0	19.0	19.4	19.6	20.0	20.1
		5	17.6	18.3	18.6	18.8	19.0	18.9
		0	16.7	17.2	17.4	17.5	17.5	17.4
		-5	15.7	16.1	16.2	16.2	16.2	16.0
		-10	14.7	14.9	15.0	15.0	14.9	14.6
		-15	13.3	13.5	13.5	13.5	13.4	13.1
		-20	11.8	11.9	11.9	11.9	11.7	11.4
		-25	10.4	10.5	10.5	10.4	10.2	9.96
		-30	9.27	9.27	9.20	9.18	9.00	8.72
		-35	8.11	8.08	8.00	7.99	7.81	7.54
		-40	6.77	6.74	6.70	6.64	6.47	6.23
-45	5.56	5.53	5.50	5.45	5.31	5.11		

容量変化表：R449A用 FWE形・FSE形・FFE形・FRE形 (ワイドレンジ)

<容量変化表> R449A FWE形・FSE形・FFE形・FRE形 (ワイドレンジ)

条件：凝縮温度別、過冷却度：0℃、過熱度変化：3.5℃時の容量[kW] / 配管やエバポレータなどの圧力損失を0とした時のものです。

製品名		凝縮温度(℃)						
		30	35	38	40	45	50	
F□E-3□□TW F□E-E3□□TW	蒸発温度(℃)	10	1.01	1.07	1.09	1.11	1.13	1.13
		5	0.98	1.02	1.04	1.04	1.05	1.05
		0	0.92	0.95	0.96	0.96	0.97	0.96
		-5	0.86	0.88	0.89	0.89	0.89	0.88
		-10	0.80	0.81	0.82	0.82	0.81	0.80
		-15	0.72	0.73	0.73	0.73	0.72	0.71
		-20	0.64	0.64	0.64	0.64	0.63	0.62
		-25	0.56	0.56	0.56	0.56	0.55	0.53
		-30	0.50	0.50	0.50	0.49	0.48	0.47
		-35	0.43	0.43	0.43	0.43	0.42	0.40
		-40	0.36	0.36	0.35	0.35	0.34	0.33
-45	0.28	0.28	0.28	0.27	0.27	0.25		
製品名		凝縮温度(℃)						
		30	35	38	40	45	50	
F□E-5□□TW F□E-E5□□TW	蒸発温度(℃)	10	1.93	2.04	2.09	2.11	2.15	2.16
		5	1.90	1.98	2.01	2.02	2.05	2.04
		0	1.79	1.85	1.87	1.88	1.89	1.87
		-5	1.69	1.73	1.74	1.74	1.74	1.72
		-10	1.58	1.60	1.61	1.61	1.60	1.57
		-15	1.43	1.45	1.45	1.45	1.43	1.40
		-20	1.27	1.28	1.28	1.27	1.25	1.22
		-25	1.11	1.12	1.11	1.11	1.09	1.06
		-30	0.99	0.99	0.98	0.97	0.96	0.92
		-35	0.86	0.86	0.85	0.84	0.83	0.80
		-40	0.72	0.72	0.71	0.70	0.69	0.66
-45	0.62	0.61	0.61	0.60	0.59	0.56		
製品名		凝縮温度(℃)						
		30	35	38	40	45	50	
F□E-10□□TW F□E-E10□□TW	蒸発温度(℃)	10	3.18	3.36	3.43	3.47	3.54	3.55
		5	3.12	3.25	3.30	3.33	3.36	3.35
		0	2.93	3.02	3.06	3.07	3.08	3.05
		-5	2.75	2.81	2.83	2.84	2.83	2.79
		-10	2.56	2.60	2.61	2.61	2.59	2.55
		-15	2.32	2.34	2.35	2.34	2.32	2.27
		-20	2.05	2.06	2.06	2.05	2.02	1.97
		-25	1.79	1.80	1.79	1.79	1.76	1.70
		-30	1.59	1.59	1.58	1.57	1.54	1.49
		-35	1.38	1.37	1.36	1.36	1.32	1.28
		-40	1.14	1.14	1.13	1.12	1.09	1.05
-45	0.96	0.95	0.94	0.93	0.91	0.87		
製品名		凝縮温度(℃)						
		30	35	38	40	45	50	
F□E-15□□TW F□E-E15□□TW	蒸発温度(℃)	10	6.38	6.74	6.89	6.98	7.10	7.12
		5	6.26	6.52	6.62	6.68	6.74	6.72
		0	5.90	6.08	6.14	6.18	6.20	6.14
		-5	5.52	5.65	5.69	5.70	5.69	5.61
		-10	5.13	5.22	5.24	5.24	5.21	5.11
		-15	4.65	4.71	4.71	4.71	4.66	4.55
		-20	4.12	4.15	4.14	4.13	4.07	3.97
		-25	3.62	3.63	3.62	3.60	3.54	3.44
		-30	3.21	3.21	3.19	3.17	3.11	3.01
		-35	2.79	2.78	2.76	2.75	2.68	2.59
		-40	2.32	2.31	2.29	2.27	2.21	2.13
-45	1.90	1.89	1.87	1.85	1.80	1.73		
製品名		凝縮温度(℃)						
		30	35	38	40	45	50	
F□E-20□□TW F□E-E20□□TW	蒸発温度(℃)	10	7.73	8.16	8.35	8.45	8.60	8.62
		5	7.62	7.93	8.06	8.12	8.21	8.17
		0	7.18	7.40	7.49	7.52	7.55	7.48
		-5	6.73	6.88	6.93	6.95	6.93	6.83
		-10	6.24	6.35	6.37	6.38	6.33	6.22
		-15	5.66	5.72	5.73	5.72	5.66	5.53
		-20	5.00	5.03	5.03	5.01	4.94	4.82
		-25	4.39	4.40	4.39	4.37	4.29	4.17
		-30	3.89	3.89	3.87	3.85	3.77	3.65
		-35	3.38	3.37	3.34	3.32	3.25	3.13
		-40	2.80	2.78	2.76	2.74	2.67	2.57
-45	2.28	2.26	2.24	2.22	2.16	2.07		

製品名		凝縮温度(℃)						
		30	35	38	40	45	50	
F□E-25□□TW F□E-E25□□TW	蒸発温度(℃)	10	9.69	10.2	10.5	10.6	10.8	10.8
		5	9.49	9.9	10.0	10.1	10.2	10.2
		0	8.95	9.23	9.33	9.38	9.41	9.32
		-5	8.40	8.59	8.66	8.68	8.66	8.54
		-10	7.82	7.95	7.98	7.99	7.93	7.79
		-15	7.09	7.17	7.18	7.17	7.09	6.94
		-20	6.26	6.30	6.30	6.28	6.19	6.03
		-25	5.49	5.51	5.49	5.47	5.37	5.22
		-30	4.86	4.86	4.84	4.81	4.71	4.56
		-35	4.23	4.22	4.19	4.16	4.07	3.93
		-40	3.53	3.51	3.48	3.45	3.36	3.24
-45	2.96	2.94	2.91	2.88	2.80	2.69		
製品名		凝縮温度(℃)						
		30	35	38	40	45	50	
F□E-30□□TW F□E-E30□□TW	蒸発温度(℃)	10	13.3	14.0	14.4	14.5	14.8	14.8
		5	13.0	13.6	13.8	13.9	14.1	14.0
		0	12.3	12.7	12.8	12.9	12.9	12.8
		-5	11.5	11.8	11.9	11.9	11.9	11.7
		-10	10.7	10.9	11.0	11.0	10.9	10.7
		-15	9.77	9.88	9.90	9.88	9.78	9.56
		-20	8.65	8.71	8.70	8.68	8.56	8.34
		-25	7.59	7.61	7.59	7.56	7.43	7.21
		-30	6.72	6.72	6.69	6.65	6.52	6.31
		-35	5.86	5.84	5.80	5.76	5.63	5.43
		-40	4.90	4.87	4.83	4.79	4.67	4.49
-45	4.18	4.15	4.12	4.09	3.98	3.83		
製品名		凝縮温度(℃)						
		30	35	38	40	45	50	
F□E-40□□TW F□E-E40□□TW	蒸発温度(℃)	10	15.9	16.8	17.2	17.4	17.7	17.7
		5	15.6	16.3	16.5	16.6	16.8	16.7
		0	14.7	15.2	15.3	15.4	15.5	15.3
		-5	13.8	14.1	14.2	14.3	14.3	14.1
		-10	12.9	13.1	13.2	13.2	13.1	12.8
		-15	11.7	11.9	11.9	11.9	11.8	11.5
		-20	10.4	10.5	10.5	10.5	10.3	10.1
		-25	9.20	9.23	9.20	9.17	9.01	8.75
		-30	8.19	8.19	8.14	8.10	7.94	7.68
		-35	7.15	7.13	7.08	7.03	6.87	6.63
		-40	5.96	5.93	5.88	5.83	5.68	5.47
-45	4.87	4.84	4.80	4.77	4.64	4.47		
製品名		凝縮温度(℃)						
		30	35	38	40	45	50	
F□E-50□□TW F□E-E50□□TW	蒸発温度(℃)	10	17.6	18.6	19.0	19.2	19.6	19.6
		5	17.2	17.9	18.2	18.4	18.6	18.5
		0	16.3	16.8	17.0	17.1	17.1	17.0
		-5	15.4	15.7	15.8	15.9	15.8	15.6
		-10	14.3	14.6	14.6	14.6	14.5	14.3
		-15	13.0	13.2	13.2	13.2	13.1	12.8
		-20	11.6	11.7	11.6	11.6	11.5	11.2
		-25	10.2	10.2	10.2	10.2	10.0	9.69
		-30	9.07	9.07	9.00	8.97	8.79	8.51
		-35	7.92	7.90	7.80	7.79	7.61	7.35
		-40	6.62	6.58	6.50	6.47	6.31	6.07
-45	5.45	5.42	5.40	5.33	5.19	5.00		

容量変化表：R407H用 FWE形・FSE形・FFE形・FRE形（ワイドレンジ）

＜容量変化表＞ R407H FWE形・FSE形・FFE形・FRE形（ワイドレンジ）

条件：凝縮温度別、過冷却度：0℃、過熱度変化：3.5℃時の容量[kW] / 配管やエバポレータなどの圧力損失を0とした時のものです。

製品名	蒸発温度(℃)	凝縮温度(℃)					
		30	35	38	40	45	50
F□E-3□□TW F□E-E3□□TW	10	1.20	1.27	1.31	1.33	1.36	1.38
	5	1.16	1.21	1.24	1.25	1.27	1.28
	0	1.10	1.14	1.16	1.17	1.18	1.18
	-5	1.03	1.06	1.08	1.08	1.09	1.09
	-10	0.95	0.98	0.98	0.99	0.99	0.99
	-15	0.86	0.88	0.89	0.89	0.89	0.88
	-20	0.77	0.78	0.79	0.79	0.79	0.78
	-25	0.68	0.69	0.69	0.69	0.69	0.68
	-30	0.60	0.61	0.61	0.61	0.60	0.59
	-35	0.52	0.53	0.53	0.53	0.52	0.51
	-40	0.44	0.44	0.44	0.44	0.43	0.42
-45	0.33	0.33	0.32	0.32	0.31	0.30	
F□E-5□□TW F□E-E5□□TW	10	2.29	2.43	2.50	2.53	2.60	2.63
	5	2.24	2.35	2.40	2.43	2.47	2.49
	0	2.14	2.22	2.25	2.27	2.30	2.31
	-5	2.02	2.08	2.10	2.12	2.13	2.13
	-10	1.88	1.92	1.94	1.95	1.96	1.94
	-15	1.71	1.74	1.76	1.76	1.76	1.75
	-20	1.53	1.56	1.56	1.57	1.56	1.54
	-25	1.35	1.37	1.37	1.37	1.37	1.35
	-30	1.19	1.20	1.21	1.21	1.20	1.18
	-35	1.04	1.05	1.05	1.04	1.03	1.01
	-40	0.88	0.88	0.88	0.88	0.87	0.85
-45	0.68	0.67	0.67	0.66	0.64	0.61	
F□E-10□□TW F□E-E10□□TW	10	3.76	3.99	4.10	4.17	4.28	4.33
	5	3.68	3.86	3.94	3.98	4.06	4.09
	0	3.50	3.63	3.69	3.72	3.77	3.77
	-5	3.28	3.38	3.43	3.45	3.48	3.47
	-10	3.04	3.11	3.14	3.16	3.17	3.15
	-15	2.76	2.82	2.84	2.85	2.85	2.82
	-20	2.47	2.51	2.53	2.53	2.52	2.49
	-25	2.18	2.21	2.22	2.22	2.21	2.17
	-30	1.92	1.94	1.94	1.94	1.93	1.90
	-35	1.66	1.68	1.68	1.67	1.66	1.63
	-40	1.39	1.40	1.40	1.40	1.38	1.35
-45	1.05	1.04	1.03	1.02	0.99	0.95	
F□E-15□□TW F□E-E15□□TW	10	7.56	8.02	8.24	8.37	8.59	8.70
	5	7.39	7.75	7.91	8.00	8.15	8.21
	0	7.03	7.29	7.41	7.47	7.57	7.58
	-5	6.60	6.80	6.88	6.93	6.98	6.97
	-10	6.10	6.25	6.31	6.34	6.37	6.33
	-15	5.55	5.66	5.70	5.71	5.72	5.66
	-20	4.97	5.05	5.08	5.08	5.07	5.01
	-25	4.40	4.46	4.47	4.47	4.45	4.38
	-30	3.89	3.92	3.93	3.93	3.90	3.83
	-35	3.37	3.40	3.40	3.39	3.36	3.29
	-40	2.82	2.84	2.84	2.83	2.80	2.74
-45	2.12	2.11	2.08	2.07	2.01	1.92	
F□E-20□□TW F□E-E20□□TW	10	9.15	9.71	9.98	10.1	10.4	10.5
	5	9.00	9.43	9.62	9.73	9.92	9.99
	0	8.56	8.88	9.03	9.10	9.22	9.24
	-5	8.04	8.28	8.38	8.43	8.50	8.48
	-10	7.42	7.60	7.68	7.71	7.74	7.70
	-15	6.74	6.87	6.92	6.94	6.95	6.88
	-20	6.04	6.13	6.16	6.17	6.16	6.08
	-25	5.34	5.41	5.42	5.43	5.40	5.32
	-30	4.71	4.75	4.76	4.76	4.72	4.64
	-35	4.08	4.11	4.11	4.10	4.06	3.98
	-40	3.41	3.42	3.42	3.41	3.37	3.30
-45	2.54	2.52	2.49	2.47	2.40	2.30	

製品名	蒸発温度(℃)	凝縮温度(℃)					
		30	35	38	40	45	50
F□E-25□□TW F□E-E25□□TW	10	11.5	12.2	12.5	12.7	13.0	13.2
	5	11.2	11.8	12.0	12.1	12.4	12.4
	0	10.7	11.1	11.3	11.4	11.5	11.5
	-5	10.0	10.3	10.5	10.5	10.6	10.6
	-10	9.30	9.53	9.62	9.66	9.70	9.64
	-15	8.45	8.62	8.68	8.70	8.71	8.63
	-20	7.56	7.68	7.72	7.73	7.71	7.62
	-25	6.68	6.76	6.78	6.79	6.75	6.65
	-30	5.89	5.95	5.96	5.95	5.91	5.81
	-35	5.11	5.15	5.15	5.14	5.09	4.99
	-40	4.30	4.32	4.31	4.30	4.25	4.16
-45	3.26	3.24	3.20	3.18	3.08	2.96	
F□E-30□□TW F□E-E30□□TW	10	15.7	16.7	17.2	17.4	17.9	18.1
	5	15.4	16.2	16.5	16.7	17.0	17.1
	0	14.6	15.2	15.4	15.6	15.8	15.8
	-5	13.8	14.2	14.4	14.4	14.6	14.5
	-10	12.8	13.1	13.2	13.3	13.3	13.2
	-15	11.7	11.9	12.0	12.0	12.0	11.9
	-20	10.5	10.6	10.7	10.7	10.7	10.5
	-25	9.23	9.35	9.38	9.38	9.33	9.20
	-30	8.14	8.22	8.24	8.23	8.17	8.03
	-35	7.08	7.13	7.13	7.12	7.05	6.91
	-40	5.96	5.99	5.99	5.97	5.90	5.78
-45	4.48	4.50	4.50	4.49	4.43	4.34	
F□E-40□□TW F□E-E40□□TW	10	18.8	20.0	20.5	20.8	21.4	21.7
	5	18.4	19.3	19.7	19.9	20.3	20.5
	0	17.5	18.2	18.5	18.7	18.9	18.9
	-5	16.5	17.0	17.2	17.3	17.5	17.4
	-10	15.3	15.7	15.9	15.9	16.0	15.9
	-15	14.0	14.3	14.4	14.4	14.4	14.3
	-20	12.6	12.8	12.9	12.9	12.9	12.7
	-25	11.2	11.3	11.4	11.4	11.3	11.2
	-30	9.92	10.0	10.0	10.0	9.95	9.78
	-35	8.63	8.69	8.70	8.68	8.60	8.43
	-40	7.26	7.30	7.29	7.27	7.19	7.03
-45	5.38	5.40	5.40	5.38	5.32	5.21	
F□E-50□□TW F□E-E50□□TW	10	20.8	22.1	22.7	23.0	23.7	24.0
	5	20.4	21.3	21.8	22.0	22.4	22.6
	0	19.4	20.2	20.5	20.7	20.9	21.0
	-5	18.3	18.9	19.1	19.3	19.4	19.4
	-10	17.1	17.5	17.6	17.7	17.8	17.7
	-15	15.6	15.9	16.0	16.0	16.0	15.9
	-20	14.0	14.2	14.3	14.3	14.3	14.1
	-25	12.4	12.6	12.6	12.6	12.5	12.4
	-30	11.0	11.1	11.1	11.1	11.0	10.8
	-35	9.57	9.63	9.60	9.62	9.53	9.34
	-40	8.06	8.10	8.10	8.07	7.98	7.80
-45	6.00	6.03	6.00	6.01	5.93	5.81	