

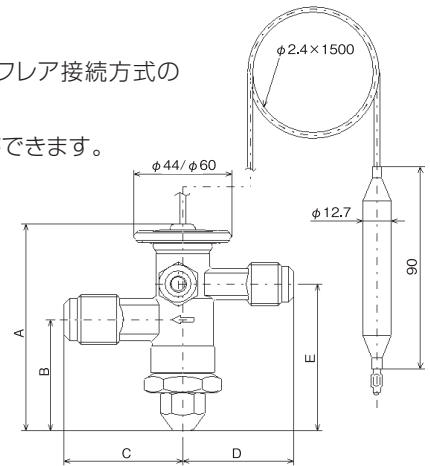

## JBE形温度膨張弁

- ホットガスデフロストサイクルにも使用可能なフレア接続方式の中容量温度膨張弁です。
- また使用目的によって蒸発温度を自由に選択ができます。

JBE-E形  
(外部均圧式)



用途	ヒートポンプ・冷房・空調・冷蔵・冷凍・環境装置など広範囲に使用可能です。 ホットガス デフロストサイクル用としても最適です。			
蒸発温度範囲	記号	ワイドレンジ W	中温 M	低温 L
	R134a	10℃～-30℃	-1℃～-30℃	-18℃～-30℃
	R407C	10℃～-40℃	-1℃～-40℃	-18℃～-40℃
	R404A	10℃～-45℃	-1℃～-45℃	-18℃～-45℃
	R410A	10℃～-45℃	—	—
R448A R449A R407H	10℃～-45℃	—	—	
静止過熱度調節範囲(※)	1～7℃ (通常は調節不要です)			
工場出荷設定値(※)	静止過熱度：3.5～4.5℃			
最高使用圧力	R134a/R407C/R404A/R448A/R449A/R407H:2.75MPaG R410A:3.3MPaG			
気密圧力	R134a/R407C/R404A/R448A/R449A/R407H:2.95MPaG R410A:3.4MPaG			
耐圧圧力	R134a/R407C/R404A/R448A/R449A/R407H:4.42MPaG R410A:4.5MPaG			
感温筒封入方式	ガスクロスチャージ			
使用最高温度	120℃			
接続方式	フレア式			
ダイアフラム径	R134a/R404A:10.6～26.4kW R407C:17.6～44.0kW R410A:21.1～56.3kW R448A/R449A/R407H:22.9～44.0kW			φ44mm
	R134a/R404A:35.2kW以上 R407C:52.7kW以上 R448A/R449A/R407H:52.7～70.3kW			φ60mm
質量	R134a/R404A:10.6～26.4kW R407C:17.6～44.0kW R410A:21.1～56.3kW R448A/R449A/R407H:22.9～44.0kW			630g(外部均圧式)
	R134a/R404A:35.2kW以上 R407C:52.7kW以上 R448A/R449A/R407H:52.7～70.3kW			960g(外部均圧式)

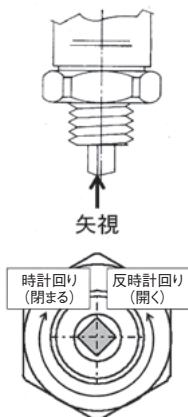

- 配管の気密を確認する際は、膨張弁に気密圧力以上の圧力がかからないよう注意して下さい。
- R410A用をヒートポンプ回路にて使用される場合は、膨張弁の感温筒と外均管を四方弁と圧縮機入り口側アキュムレータの間に取付けて下さい。  
(※)R407C用は旧R22用をベースに設定されておりますので、若干カタログ値と異なります。  
(※)R448A、R449A、R407H用はR448A、R449Aをベースに設定されております。工場出荷状態でR407Hを使用される場合、静止過熱度は1.5～2.5℃となります。3.5～4.5℃で使用するには調節ネジにて調節して下さい。
- 調節ネジは、矢視方向より時計回りが閉まり方向(過熱度増)、反時計回りが開き方向(過熱度減)です。時計回り方向に、調節範囲を超えて回し続けると調節できなくなる場合がありますので注意して下さい。
- 調整後は必ずキャップを戻して下さい。調節ネジ用キャップの締め付けトルクは8～10N・mです。

### 調節ネジ1回転あたりの圧力変化量

ダイアフラム部径	圧力変化量
φ44	約0.020MPa
φ60	約0.010MPa

仕 様

形 式	公称 容量 kW	接続配管径 入口×出口mm(インチ)	使用冷媒					ダイヤフラム径	寸法 mm										
			R134a	R407C	R404A	R410A	R448A R449A R407H		A	B	C	D	E						
JBE-E 3034□□	10.6	9.52(3/8)×12.70(1/2)	○	/	○	/	/	φ 44	92	49.5	49	46.5	65.5						
JBE-E 4034□□	14.1		○	/	○	/	/												
JBE-E 5034□□	17.6		/	○	/	/	/												
JBE-E 6034□□	21.1		/	/	/	○	/												
JBE-E 6534□□	22.9		/	○	/	/	○												
JBE-E 8034□□	28.1		/	/	/	○	/												
JBE-E3045□□	10.6	12.70(1/2)×15.88(5/8)	○	/	○	/	/												
JBE-E4045□□	14.1		○	/	○	/	/												
JBE-E5045□□	17.6		○	○	○	/	/												
JBE-E6045□□	21.1		○	/	○	○	/												
JBE-E6545□□	22.9		/	○	/	/	○												
JBE-E7545□□	26.4		○	/	○	/	/												
JBE-E8045□□	28.1		/	○	/	○	○												
JBE-E10045□□	35.2		○	○	○	○	○												
JBE-E12545□□	44.0		/	○	/	/	○												
JBE-E3056□□	10.6		15.88(5/8)×19.05(3/4)	○	/	○	/		/	φ 44	92	49.5	56.5	53	65.5				
JBE-E4056□□	14.1	○		/	○	/	/												
JBE-E5056□□	17.6	○		○	○	/	/												
JBE-E6056□□	21.1	○		/	○	○	/												
JBE-E6556□□	22.9	/		○	/	/	○												
JBE-E7556□□	26.4	○		/	○	/	/												
JBE-E8056□□	28.1	/		○	/	○	○												
JBE-E10056□□	35.2	/		/	/	○	○												
JBE-E12056□□	42.2	/		/	/	○	○												
JBE-E14056□□	49.2	/		/	/	○	○												
JBE-E16056□□	56.3	/		/	/	○	○												
JBE-E10056□□	35.2	○		○	○	/	/	φ 60	107							55	60.5	56	73.5
JBE-E12556□□	44.0	○		○	○	/	/												
JBE-E15056□□	52.7	/		○	/	/	○												
JBE-E20056□□	70.3	○	○	○	/	○													

形式と記号

Jシリーズの各膨張弁の形式は、次の表示がされています。

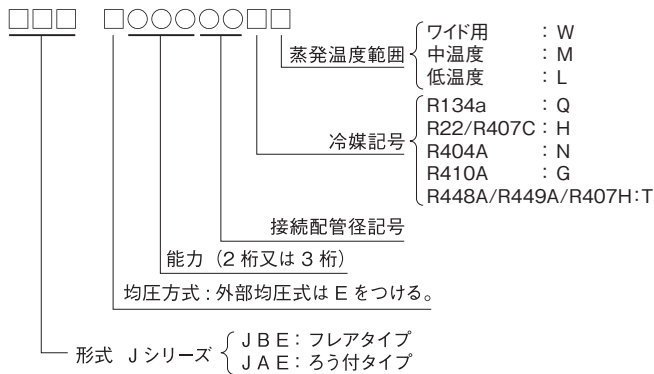

<容量変化表> R134a用 JBE形・JAE形 (代表:ワイドレンジ)

条件：凝縮温度別、過冷却度：0℃、過熱度変化：4℃時の容量 [ kW ]

配管やエバポレータなどの圧力損失を0とした時のものです。

製品名		凝縮温度 (°C)						
		30	35	38	40	45	50	
J□E-E30□□QW	蒸発温度 (°C)	10	11.9	13.0	13.5	13.8	14.5	14.9
		5	11.3	12.1	12.4	12.7	13.1	13.4
		0	10.7	11.3	11.6	11.7	12.1	12.2
		-5	9.9	10.3	10.5	10.6	10.9	10.9
		-10	8.7	9.0	9.1	9.2	9.4	9.4
		-15	7.5	7.8	7.9	7.9	8.0	8.0
		-20	6.6	6.7	6.8	6.8	6.9	6.8
		-25	5.8	6.0	6.0	6.0	6.0	6.0
		-30	5.7	5.8	5.8	5.8	5.8	5.8
製品名		凝縮温度 (°C)						
J□E-E40□□QW	蒸発温度 (°C)	10	15.4	16.8	17.5	17.9	18.7	19.3
		5	14.6	15.6	16.1	16.4	17.0	17.3
		0	13.9	14.7	15.0	15.2	15.6	15.9
		-5	12.8	13.4	13.6	13.8	14.1	14.2
		-10	11.3	11.7	11.9	12.0	12.1	12.2
		-15	9.9	10.1	10.3	10.3	10.4	10.4
		-20	8.6	8.8	8.9	8.9	9.0	8.9
		-25	7.6	7.8	7.8	7.8	7.9	7.8
		-30	7.4	7.5	7.6	7.6	7.6	7.5
製品名		凝縮温度 (°C)						
J□E-E50□□QW	蒸発温度 (°C)	10	18.7	20.5	21.3	21.8	22.8	23.5
		5	17.8	20.0	19.6	19.9	20.6	21.1
		0	16.8	17.7	18.2	18.4	18.9	19.2
		-5	15.5	16.2	16.5	16.7	17.0	17.2
		-10	13.7	14.2	14.4	14.5	14.7	14.8
		-15	12.0	12.3	12.5	12.5	12.7	12.7
		-20	10.4	10.7	10.8	10.8	10.9	10.9
		-25	9.3	9.4	9.5	9.5	9.6	9.5
		-30	9.0	9.2	9.2	9.2	9.2	9.1
製品名		凝縮温度 (°C)						
J□E-E60□□QW	蒸発温度 (°C)	10	21.2	23.2	24.1	24.7	25.8	26.6
		5	20.2	21.6	22.3	22.7	23.5	23.9
		0	19.2	20.2	20.7	21.0	21.6	21.9
		-5	17.7	18.4	18.8	19.0	19.4	19.5
		-10	15.6	16.1	16.4	16.5	16.8	16.8
		-15	13.7	14.1	14.2	14.3	14.5	14.5
		-20	11.9	12.2	12.3	12.4	12.4	12.4
		-25	10.6	10.8	10.9	10.9	11.0	10.9
		-30	10.3	10.5	10.6	10.6	10.6	10.5

製品名		凝縮温度 (°C)						
		30	35	38	40	45	50	
J□E-E75□□QW	蒸発温度 (°C)	10	25.7	28.0	29.2	29.9	31.2	32.1
		5	24.2	25.9	26.7	27.2	28.1	28.7
		0	23.1	24.4	25.0	25.4	26.0	26.4
		-5	21.3	22.3	22.7	23.0	23.4	23.6
		-10	18.9	19.5	19.8	20.0	20.3	20.5
		-15	16.6	17.0	17.2	17.4	17.5	17.5
		-20	14.4	14.8	14.9	15.0	15.1	15.0
		-25	12.9	13.1	13.2	13.2	13.3	13.2
		-30	12.5	12.7	12.8	12.8	12.8	12.7
製品名		凝縮温度 (°C)						
J□E-E100□□QW	蒸発温度 (°C)	10	32.1	35.1	36.5	37.4	39.1	40.2
		5	31.1	33.3	34.3	35.0	36.2	36.9
		0	28.3	29.8	30.6	31.0	31.8	32.2
		-5	25.3	26.4	26.9	27.2	27.7	28.0
		-10	22.2	23.0	23.4	23.6	23.9	24.0
		-15	20.2	20.8	21.0	21.2	21.4	21.4
		-20	17.6	18.0	18.2	18.3	18.4	18.3
		-25	15.9	16.2	16.3	16.3	16.4	16.2
		-30	14.3	14.5	14.6	14.6	14.6	14.4
製品名		凝縮温度 (°C)						
J□E-E120□□QW	蒸発温度 (°C)	10	41.3	45.1	47.0	48.1	50.2	51.7
		5	40.0	42.8	44.2	44.9	46.5	47.5
		0	36.5	38.4	39.4	40.0	41.0	41.6
		-5	32.7	34.1	34.8	35.2	35.9	36.2
		-10	28.8	29.8	30.3	30.5	31.0	31.1
		-15	26.3	27.0	27.4	27.6	27.8	27.8
		-20	22.9	23.4	23.6	23.7	23.9	23.8
		-25	20.6	21.0	21.2	21.2	21.3	21.1
		-30	18.6	18.9	19.0	19.1	19.0	18.8
製品名		凝縮温度 (°C)						
J□E-E200□□QW	蒸発温度 (°C)	10	59.9	65.4	68.1	69.6	72.8	74.9
		5	58.0	62.0	64.0	65.1	67.4	68.8
		0	53.2	56.1	57.5	58.3	59.9	60.7
		-5	47.9	50.0	51.0	51.6	52.6	53.0
		-10	42.4	43.9	44.6	45.0	45.6	45.8
		-15	38.9	40.0	40.5	40.8	41.1	41.1
		-20	33.9	34.7	35.1	35.3	35.4	35.3
		-25	30.8	31.4	31.6	31.8	31.8	31.6
		-30	28.0	28.4	28.6	28.6	28.6	28.3

容量変化表：R407C用 JBE形・JAE形 (代表:ワイドレンジ)

<容量変化表> R407C用 JBE形・JAE形 (代表:ワイドレンジ)

条件：凝縮温度別、過冷却度：0℃、過熱度変化：3.5℃時の容量 [ kW ]  
 配管やエバポレータなどの圧力損失を0とした時のものです。

製品名	蒸発温度 (°C)	凝縮温度 (°C)					
		30	35	38	40	45	50
J□E-E50□□HW	10	20.6	21.4	22.5	22.8	22.8	23.7
	5	20.2	20.7	21.5	21.8	21.7	22.3
	0	19.4	19.7	20.4	20.5	20.3	20.8
	-5	18.3	18.5	19.1	19.2	18.9	19.3
	-10	17.2	17.2	17.7	17.8	17.4	17.7
	-15	15.5	15.5	15.9	15.9	15.5	15.7
	-20	14.2	14.0	14.4	14.4	14.0	14.2
	-25	12.6	12.5	12.8	12.7	12.4	12.5
	-30	11.2	11.0	11.2	11.2	10.8	10.9
	-35	10.1	9.9	10.1	10.1	9.7	9.8
	-40	9.1	8.9	9.1	9.0	8.7	8.7
J□E-E65□□HW	10	26.7	27.7	29.1	29.5	29.6	30.6
	5	26.2	26.8	28.0	28.2	28.1	28.9
	0	25.2	25.6	26.5	26.7	26.4	27.0
	-5	23.7	23.9	24.7	24.8	24.4	24.9
	-10	22.5	22.5	23.2	23.3	22.8	23.2
	-15	20.2	20.1	20.7	20.7	20.2	20.5
	-20	18.5	18.4	18.8	18.8	18.3	18.5
	-25	16.3	16.1	16.5	16.5	16.0	16.1
	-30	14.6	14.3	14.7	14.7	14.1	14.2
	-35	13.2	13.0	13.3	13.2	12.7	12.8
	-40	11.8	11.5	11.8	11.7	11.2	11.3
J□E-E80□□HW	10	32.5	33.8	35.4	35.9	36.0	37.3
	5	31.9	32.7	34.0	34.4	34.2	35.2
	0	30.7	31.1	32.3	32.5	32.2	33.0
	-5	28.8	29.0	30.0	30.2	29.7	30.3
	-10	27.4	27.4	28.2	28.3	27.7	28.2
	-15	24.5	24.4	25.0	25.1	24.5	24.8
	-20	22.6	22.4	23.0	23.0	22.3	22.6
	-25	20.0	19.7	20.2	20.2	19.6	19.7
	-30	17.8	17.5	17.9	17.9	17.3	17.4
	-35	16.1	15.8	16.2	16.1	15.5	15.6
	-40	14.4	14.1	14.3	14.3	13.7	13.8
J□E-E100□□HW	10	37.1	38.5	40.4	40.9	41.1	42.5
	5	36.3	37.2	38.7	39.1	38.9	40.1
	0	35.0	35.5	36.8	37.1	36.7	37.6
	-5	32.9	33.1	34.2	34.4	33.9	34.5
	-10	31.2	31.3	32.2	32.3	31.6	32.2
	-15	28.0	27.9	28.7	28.7	28.0	28.4
	-20	25.7	25.5	26.1	26.2	25.4	25.7
	-25	22.8	22.5	23.1	23.1	22.3	22.5
	-30	20.3	20.0	20.4	20.4	19.7	19.8
	-35	18.3	18.0	18.4	18.3	17.6	17.7
	-40	16.5	16.1	16.4	16.4	15.7	15.8

製品名	蒸発温度 (°C)	凝縮温度 (°C)					
		30	35	38	40	45	50
J□E-E125□□HW	10	42.8	44.4	46.6	47.2	47.4	49.1
	5	41.8	42.8	44.6	45.1	44.9	46.2
	0	40.2	40.7	42.3	42.6	42.1	43.1
	-5	37.9	38.2	39.4	39.7	39.0	39.8
	-10	35.9	36.0	37.1	37.2	36.4	37.0
	-15	32.3	32.2	33.1	33.1	32.3	32.8
	-20	29.8	29.5	30.3	30.3	29.4	29.8
	-25	26.5	26.2	26.8	26.8	26.0	26.2
	-30	23.7	23.3	23.9	23.8	23.0	23.1
	-35	21.4	21.0	21.5	21.4	20.6	20.7
	-40	19.3	18.9	19.3	19.2	18.4	18.5
J□E-E150□□HW	10	53.5	55.5	58.2	59.0	59.1	61.3
	5	53.3	54.5	56.8	57.4	57.1	58.8
	0	49.6	50.3	52.2	52.6	52.0	53.2
	-5	47.1	47.5	49.0	49.3	48.5	49.5
	-10	43.1	43.1	44.5	44.6	43.7	44.4
	-15	39.3	39.1	40.2	40.3	39.3	39.8
	-20	36.4	36.1	37.1	37.1	36.0	36.4
	-25	32.1	31.7	32.5	32.5	31.5	31.7
	-30	29.6	29.1	29.8	29.7	28.7	28.9
	-35	25.7	25.2	25.7	25.7	24.7	24.8
	-40	22.3	21.9	22.3	22.2	21.4	21.4
J□E-E200□□HW	10	69.2	71.8	75.3	76.4	76.6	79.4
	5	69.0	70.6	73.6	74.4	74.0	76.2
	0	64.1	65.1	67.5	68.0	67.2	68.9
	-5	61.1	61.5	63.6	63.9	62.9	64.1
	-10	56.0	56.0	57.7	57.9	56.7	57.7
	-15	51.1	50.9	52.3	52.4	51.1	51.8
	-20	47.3	46.9	48.2	48.2	46.8	47.3
	-25	41.9	41.3	42.4	42.3	41.0	41.3
	-30	38.5	37.9	38.8	38.7	37.4	37.6
	-35	33.5	32.9	33.6	33.5	32.3	32.4
	-40	29.2	28.5	29.1	29.0	27.9	27.9
J□E-E300□□HW	10	101.4	105.2	110.3	111.9	112.2	116.2
	5	100.8	103.2	107.6	108.7	108.2	111.4
	0	94.1	95.5	99.0	99.8	98.7	101.1
	-5	90.0	90.6	93.6	94.1	92.6	94.5
	-10	82.7	82.8	85.3	85.6	83.8	85.2
	-15	75.9	75.5	77.6	77.8	75.9	76.9
	-20	70.5	69.9	71.7	71.8	69.8	70.5
	-25	62.7	61.9	63.4	63.4	61.4	61.9
	-30	57.8	56.9	58.2	58.1	56.1	56.4
	-35	50.4	49.4	50.5	50.4	48.5	48.7
	-40	44.1	43.2	44.1	43.9	42.2	42.3

<容量変化表> R404A用 JBE形・JAE形 (代表:ワイドレンジ)

条件：凝縮温度別、過冷却度：0℃、過熱度変化：3.5℃時の容量 [kW]

配管やエバポレータなどの圧力損失を0とした時のものです。

製品名		凝縮温度 (°C)						
		30	35	38	40	45	50	
J□E-E30□□NW	蒸発温度 (°C)	10	15.1	16.1	16.3	16.5	16.7	16.4
		5	14.9	15.6	15.7	15.8	15.7	15.3
		0	13.9	14.3	14.4	14.4	14.3	13.8
		-5	13.4	13.7	13.6	13.6	13.3	12.8
		-10	12.4	12.5	12.4	12.4	12.1	11.5
		-15	11.2	11.2	11.1	11.0	10.7	10.2
		-20	9.9	9.8	9.7	9.6	9.3	8.8
		-25	9.0	8.9	8.7	8.6	8.3	7.8
		-30	7.5	7.4	7.3	7.2	6.9	6.4
		-35	6.6	6.5	6.3	6.2	5.9	5.5
		-40	5.8	5.7	5.5	5.5	5.2	4.8
		-45	4.6	4.5	4.4	4.3	4.1	3.8
製品名		凝縮温度 (°C)						
J□E-E40□□NW	蒸発温度 (°C)	10	19.5	20.9	21.2	21.4	21.7	21.3
		5	19.3	20.2	20.4	20.5	20.3	19.9
		0	18.1	18.6	18.7	18.7	18.5	17.9
		-5	17.4	17.7	17.7	17.6	17.3	16.6
		-10	16.1	16.3	16.2	16.1	15.7	15.0
		-15	14.5	14.6	14.4	14.3	13.9	13.2
		-20	12.9	12.8	12.6	12.5	12.1	11.4
		-25	11.6	11.5	11.3	11.2	10.8	10.1
		-30	9.8	9.7	9.5	9.4	9.0	8.4
		-35	8.6	8.4	8.2	8.1	7.7	7.2
		-40	7.6	7.4	7.2	7.1	6.8	6.2
		-45	6.0	5.9	5.7	5.6	5.3	4.9
製品名		凝縮温度 (°C)						
J□E-E50□□NW	蒸発温度 (°C)	10	23.7	25.3	25.7	26.0	26.3	25.8
		5	23.5	24.5	24.7	24.9	24.7	24.2
		0	22.0	22.6	22.7	22.7	22.5	21.8
		-5	21.1	21.5	21.4	21.4	21.0	20.2
		-10	19.6	19.8	19.7	19.6	19.1	18.2
		-15	17.7	17.8	17.6	17.5	17.0	16.1
		-20	15.7	15.6	15.4	15.3	14.8	13.9
		-25	14.2	14.1	13.8	13.7	13.1	12.3
		-30	12.0	11.8	11.6	11.4	11.0	10.2
		-35	10.4	10.3	10.0	9.9	9.4	8.8
		-40	9.2	9.0	8.8	8.7	8.2	7.6
		-45	7.4	7.2	7.0	6.9	6.5	6.0
製品名		凝縮温度 (°C)						
J□E-E60□□NW	蒸発温度 (°C)	10	27.0	28.8	29.3	29.6	29.9	29.4
		5	26.8	28.0	28.2	28.3	28.1	27.6
		0	25.0	25.8	25.8	25.9	25.6	24.8
		-5	24.1	24.6	24.5	24.4	24.0	23.1
		-10	22.3	22.6	22.4	22.3	21.7	20.8
		-15	20.2	20.3	20.1	19.9	19.3	18.4
		-20	17.9	17.8	17.6	17.4	16.8	15.9
		-25	16.2	16.1	15.8	15.6	15.0	14.1
		-30	13.7	13.5	13.3	13.1	12.5	11.7
		-35	11.9	11.7	11.5	11.3	10.8	10.0
		-40	10.6	10.3	10.1	9.9	9.4	8.7
		-45	8.5	8.3	8.0	7.9	7.4	6.8

製品名		凝縮温度 (°C)						
		30	35	38	40	45	50	
J□E-E75□□NW	蒸発温度 (°C)	10	32.6	34.8	35.4	35.7	36.1	35.5
		5	32.2	33.7	33.9	34.1	34.0	33.2
		0	30.2	31.1	31.2	31.2	30.9	29.9
		-5	29.1	29.7	29.6	29.5	29.0	27.9
		-10	27.0	27.3	27.1	26.9	26.3	25.1
		-15	24.4	24.5	24.2	24.1	23.4	22.2
		-20	21.7	21.6	21.3	21.1	20.4	19.2
		-25	19.6	19.5	19.2	18.9	18.2	17.1
		-30	16.7	16.5	16.2	15.9	15.2	14.2
		-35	14.5	14.3	13.9	13.7	13.1	12.2
		-40	12.9	12.6	12.3	12.1	11.5	10.6
		-45	10.3	10.1	9.8	9.6	9.1	8.3
製品名		凝縮温度 (°C)						
J□E-E100□□NW	蒸発温度 (°C)	10	40.4	43.2	43.9	44.3	44.8	44.1
		5	39.7	41.5	41.8	42.0	41.9	40.9
		0	37.8	38.9	39.0	39.0	38.7	37.4
		-5	36.0	36.6	36.5	36.4	35.8	34.4
		-10	33.2	33.5	33.3	33.1	32.3	30.9
		-15	30.0	30.1	29.8	29.5	28.7	27.2
		-20	26.6	26.5	26.1	25.9	25.0	23.6
		-25	23.4	23.2	22.8	22.6	21.7	20.4
		-30	20.6	20.3	19.9	19.7	18.8	17.6
		-35	17.7	17.5	17.1	16.8	16.0	14.9
		-40	14.9	14.6	14.3	14.0	13.3	12.3
		-45	12.5	12.2	11.9	11.7	11.0	10.1
製品名		凝縮温度 (°C)						
J□E-E125□□NW	蒸発温度 (°C)	10	52.2	55.7	56.6	57.2	57.8	56.8
		5	51.2	53.6	54.0	54.3	54.1	52.8
		0	48.9	50.4	50.5	50.5	50.1	48.4
		-5	46.6	47.5	47.3	47.1	46.4	44.5
		-10	43.0	43.5	43.1	42.9	41.9	40.0
		-15	39.0	39.1	38.7	38.4	37.3	35.4
		-20	34.6	34.5	34.0	33.7	32.5	30.7
		-25	30.5	30.3	29.8	29.4	28.3	26.6
		-30	26.9	26.6	26.1	25.7	24.6	23.0
		-35	23.2	22.8	22.3	22.0	20.9	19.5
		-40	19.5	19.1	18.7	18.3	17.4	16.1
		-45	16.4	16.0	15.6	15.3	14.4	13.3
製品名		凝縮温度 (°C)						
J□E-E200□□NW	蒸発温度 (°C)	10	75.8	81.0	82.3	83.1	84.0	82.6
		5	74.7	78.0	78.7	79.1	78.8	76.9
		0	71.4	73.7	73.7	73.8	73.1	70.7
		-5	68.3	69.6	69.3	69.1	68.0	65.3
		-10	63.2	63.9	63.4	63.1	61.6	58.9
		-15	57.7	57.9	57.2	56.8	55.2	52.4
		-20	51.4	51.3	50.6	50.1	48.4	45.7
		-25	45.6	45.2	44.5	44.0	42.3	39.7
		-30	40.4	39.9	39.1	38.5	36.9	34.5
		-35	34.9	34.4	33.6	33.1	31.5	29.3
		-40	29.6	29.0	28.3	27.8	26.3	24.3
		-45	24.9	24.3	23.7	23.2	21.9	20.1

容量変化表：R410A用 JBE形・JAE形 (ワイドレンジ)

膨  
張  
弁

<容量変化表> R410A用 JBE形・JAE形 (ワイドレンジ)

条件：凝縮温度別、過冷却度：0℃、過熱度変化：3.5℃時の容量 [kW]  
配管やエバポレータなどの圧力損失を0とした時のものです。

製品名		凝縮温度 (°C)						
		30	35	38	40	45	50	
J□E-E60□□GW	蒸発温度 (°C)	10	23.6	25.5	26.1	26.5	27.4	27.2
		5	22.3	23.7	24.0	24.2	24.8	24.4
		0	20.8	21.8	22.0	22.1	22.5	22.0
		-5	20.8	21.5	21.6	21.7	21.9	21.3
		-10	20.5	21.1	21.1	21.1	21.2	20.6
		-15	18.9	19.4	19.3	19.3	19.3	18.6
		-20	16.7	17.0	16.9	16.9	16.8	16.2
		-25	15.3	15.5	15.4	15.3	15.2	14.6
		-30	13.2	13.3	13.2	13.1	13.0	12.4
		-35	12.0	12.1	11.9	11.8	11.7	11.2
		-40	11.4	11.5	11.3	11.2	11.1	10.5
		-45	9.1	9.1	9.0	8.9	8.8	8.3
		製品名		凝縮温度 (°C)				
		30	35	38	40	45	50	
J□E-E80□□GW	蒸発温度 (°C)	10	29.1	31.4	32.2	32.7	33.7	33.5
		5	27.4	29.1	29.5	29.8	30.5	30.0
		0	25.6	26.8	27.0	27.2	27.6	27.0
		-5	25.7	26.6	26.7	26.8	27.0	26.3
		-10	25.3	26.0	26.0	26.0	26.1	25.3
		-15	23.7	24.2	24.1	24.1	24.1	23.3
		-20	20.7	21.0	20.9	20.9	20.8	20.0
		-25	19.1	19.4	19.2	19.1	19.0	18.2
		-30	16.0	16.2	16.0	15.9	15.8	15.1
		-35	14.8	14.9	14.7	14.6	14.4	13.8
		-40	13.8	13.9	13.7	13.6	13.4	12.8
		-45	11.0	11.1	10.9	10.8	10.6	10.1
		製品名		凝縮温度 (°C)				
		30	35	38	40	45	50	
J□E-E100□□GW	蒸発温度 (°C)	10	34.4	37.2	38.1	38.7	39.9	39.7
		5	33.2	35.2	35.7	36.1	36.9	36.3
		0	31.4	32.8	33.1	33.3	33.8	33.1
		-5	31.4	32.6	32.7	32.8	33.1	32.3
		-10	31.0	31.9	31.9	31.9	32.1	31.1
		-15	28.9	29.5	29.4	29.4	29.4	28.4
		-20	25.0	25.5	25.3	25.3	25.1	24.2
		-25	23.3	23.6	23.4	23.3	23.2	22.2
		-30	19.1	19.3	19.1	19.0	18.8	18.0
		-35	17.7	17.8	17.6	17.5	17.3	16.5
		-40	16.7	16.8	16.6	16.5	16.2	15.5
		-45	13.2	13.2	13.0	12.9	12.7	12.0

製品名		凝縮温度 (°C)						
		30	35	38	40	45	50	
J□E-E120□□GW	蒸発温度 (°C)	10	41.1	44.4	45.5	46.2	47.7	47.4
		5	41.1	43.7	44.3	44.8	45.7	45.1
		0	38.8	40.6	40.9	41.2	41.8	40.9
		-5	39.1	40.6	40.7	40.9	41.2	40.1
		-10	39.0	40.1	40.1	40.2	40.3	39.1
		-15	37.0	37.9	37.7	37.7	37.7	36.4
		-20	33.5	34.1	33.9	33.8	33.7	32.4
		-25	31.5	32.0	31.7	31.6	31.4	30.1
		-30	26.8	27.1	26.8	26.7	26.4	25.3
		-35	25.1	26.3	25.0	24.9	24.6	23.4
		-40	23.6	23.7	23.4	23.2	22.9	21.8
		-45	19.0	19.1	18.8	18.7	18.3	17.4
		製品名		凝縮温度 (°C)				
		30	35	38	40	45	50	
J□E-E140□□GW	蒸発温度 (°C)	10	50.1	54.2	55.5	56.4	58.2	57.8
		5	48.4	51.3	52.1	52.6	53.8	53.0
		0	46.0	48.1	48.5	48.8	49.5	48.5
		-5	45.8	47.4	47.6	47.8	48.2	47.0
		-10	45.6	46.9	46.9	47.0	47.1	45.7
		-15	43.0	44.0	43.8	43.8	43.7	42.3
		-20	38.4	39.1	38.8	38.7	38.6	37.1
		-25	35.8	36.3	36.0	35.9	35.6	34.2
		-30	30.1	30.4	30.1	30.0	29.7	28.4
		-35	27.9	28.2	27.8	27.6	27.3	26.1
		-40	26.3	26.5	26.1	25.9	25.5	24.3
		-45	21.0	21.0	20.7	20.5	20.2	19.2
		製品名		凝縮温度 (°C)				
		30	35	38	40	45	50	
J□E-E160□□GW	蒸発温度 (°C)	10	57.4	62.1	63.6	64.6	66.6	66.2
		5	55.0	58.3	59.2	59.8	61.1	60.3
		0	53.2	55.6	56.1	56.5	57.3	56.1
		-5	52.4	54.3	54.5	54.7	55.2	53.8
		-10	51.9	53.4	53.4	53.5	53.7	52.1
		-15	44.8	45.8	45.6	45.6	45.5	44.0
		-20	44.2	45.0	44.7	44.6	44.4	42.8
		-25	41.4	42.0	41.6	41.5	41.2	39.5
		-30	34.9	35.3	34.9	34.7	34.4	32.9
		-35	32.3	32.5	32.1	31.9	31.5	30.1
		-40	30.6	30.7	30.3	30.1	29.7	28.2
		-45	24.3	24.4	24.0	23.8	23.4	22.2

＜容量変化表＞ R448A JBE形・JAE形（ワイドレンジ）

条件：凝縮温度別、過冷却度：0℃、過熱度変化：3.5℃時の容量[kW]  
配管やエバポレータなどの圧力損失を0とした時のものです。

製品名		凝縮温度(℃)						
		30	35	38	40	45	50	
J□E-E65□□TW	蒸発温度(℃)	10	25.0	26.4	27.0	27.3	27.8	27.9
		5	24.5	25.5	26.0	26.2	26.5	26.4
		0	23.4	24.1	24.4	24.5	24.6	24.4
		-5	22.2	22.7	22.9	23.0	22.9	22.6
		-10	20.8	21.1	21.2	21.2	21.1	20.7
		-15	19.0	19.2	19.2	19.2	19.0	18.6
		-20	16.9	17.0	17.0	17.0	16.8	16.3
		-25	15.1	15.2	15.1	15.1	14.8	14.4
		-30	13.6	13.6	13.5	13.5	13.2	12.8
		-35	12.2	12.1	12.0	12.0	11.7	11.3
		-40	10.6	10.5	10.5	10.4	10.1	9.74
-45	9.44	9.36	9.27	9.19	8.93	8.56		
製品名		凝縮温度(℃)						
		30	35	38	40	45	50	
J□E-E80□□TW	蒸発温度(℃)	10	30.4	32.1	32.8	33.2	33.8	33.9
		5	29.9	31.1	31.6	31.9	32.2	32.1
		0	28.5	29.3	29.7	29.8	29.9	29.7
		-5	27.0	27.6	27.8	27.9	27.8	27.5
		-10	25.3	25.7	25.8	25.8	25.7	25.2
		-15	23.1	23.3	23.4	23.3	23.1	22.6
		-20	20.6	20.7	20.7	20.7	20.4	19.9
		-25	18.4	18.5	18.4	18.3	18.0	17.5
		-30	16.6	16.6	16.5	16.4	16.1	15.6
		-35	14.9	14.9	14.8	14.7	14.4	13.9
		-40	13.1	13.0	12.9	12.9	12.5	12.1
-45	12.0	11.9	11.8	11.7	11.4	10.9		
製品名		凝縮温度(℃)						
		30	35	38	40	45	50	
J□E-E100□□TW	蒸発温度(℃)	10	34.7	36.6	37.5	37.9	38.6	38.7
		5	34.0	35.4	36.0	36.3	36.7	36.5
		0	32.4	33.4	33.8	33.9	34.1	33.8
		-5	30.8	31.5	31.7	31.8	31.8	31.3
		-10	28.9	29.4	29.5	29.5	29.3	28.8
		-15	26.4	26.7	26.7	26.7	26.4	25.9
		-20	23.5	23.7	23.7	23.6	23.3	22.7
		-25	20.9	21.0	21.0	20.9	20.5	20.0
		-30	18.9	18.9	18.8	18.7	18.3	17.7
		-35	16.9	16.9	16.8	16.7	16.3	15.7
		-40	15.0	14.9	14.8	14.7	14.4	13.8
-45	14.4	14.2	14.1	14.0	13.6	13.0		

製品名		凝縮温度(℃)						
		30	35	38	40	45	50	
J□E-E125□□TW	蒸発温度(℃)	10	40.0	42.2	43.2	43.7	44.6	44.7
		5	39.2	40.8	41.4	41.8	42.2	42.1
		0	37.3	38.4	38.9	39.1	39.2	38.9
		-5	35.4	36.2	36.5	36.6	36.5	36.0
		-10	33.3	33.8	34.0	34.0	33.8	33.2
		-15	30.5	30.8	30.8	30.8	30.5	29.9
		-20	27.2	27.4	27.4	27.3	27.0	26.3
		-25	24.4	24.4	24.4	24.3	23.9	23.2
		-30	22.0	22.0	21.9	21.8	21.4	20.7
		-35	19.8	19.8	19.7	19.6	19.1	18.5
		-40	17.7	17.6	17.5	17.3	16.9	16.3
-45	16.9	16.8	16.6	16.5	16.0	15.4		
製品名		凝縮温度(℃)						
		30	35	38	40	45	50	
J□E-E150□□TW	蒸発温度(℃)	10	50.0	52.8	54.0	54.7	55.7	55.8
		5	49.6	51.7	52.5	53.0	53.5	53.3
		0	46.6	48.0	48.6	48.8	49.0	48.6
		-5	43.4	44.4	44.7	44.9	44.8	44.2
		-10	40.2	40.9	41.1	41.1	40.9	40.1
		-15	36.9	37.3	37.4	37.3	37.0	36.2
		-20	33.3	33.5	33.5	33.4	33.0	32.1
		-25	29.9	30.0	29.9	29.8	29.3	28.5
		-30	27.0	27.0	26.9	26.7	26.2	25.4
		-35	24.0	23.9	23.8	23.7	23.1	22.3
		-40	20.4	20.3	20.1	20.0	19.5	18.8
-45	18.9	18.8	18.6	18.4	17.9	17.2		
製品名		凝縮温度(℃)						
		30	35	38	40	45	50	
J□E-E200□□TW	蒸発温度(℃)	10	64.7	68.3	69.9	70.7	72.1	72.3
		5	64.2	66.9	68.0	68.6	69.3	69.0
		0	60.3	62.2	62.9	63.2	63.5	62.9
		-5	56.3	57.5	58.0	58.1	58.1	57.2
		-10	52.2	53.1	53.3	53.4	53.0	52.1
		-15	47.9	48.5	48.6	48.5	48.0	47.0
		-20	43.3	43.6	43.6	43.5	42.9	41.8
		-25	39.0	39.1	39.0	38.9	38.2	37.2
		-30	35.2	35.2	35.0	34.9	34.2	33.1
		-35	31.3	31.2	31.1	30.9	30.2	29.1
		-40	26.6	26.5	26.3	26.1	25.5	24.5
-45	21.5	21.4	21.2	21.1	20.5	19.8		

＜容量変化表＞ R449A JBE形・JAE形 (ワイドレンジ)

条件：凝縮温度別、過冷却度：0℃、過熱度変化：3.5℃時の容量[kW]

配管やエバポレータなどの圧力損失を0とした時のものです。

製品名		凝縮温度(℃)						
		30	35	38	40	45	50	
J□E-E65□□TW	蒸発温度(℃)	10	24.5	25.8	26.4	26.7	27.2	27.3
		5	24.0	25.0	25.4	25.6	25.9	25.8
		0	22.9	23.6	23.9	24.0	24.1	23.8
		-5	21.7	22.2	22.4	22.4	22.4	22.1
		-10	20.3	20.7	20.8	20.8	20.6	20.3
		-15	18.5	18.8	18.8	18.8	18.6	18.1
		-20	16.6	16.7	16.7	16.6	16.4	16.0
		-25	14.7	14.8	14.7	14.7	14.4	14.0
		-30	13.3	13.3	13.2	13.2	12.9	12.5
		-35	11.9	11.8	11.8	11.7	11.4	11.0
		-40	10.3	10.3	10.2	10.1	9.90	9.48
-45	9.24	9.16	9.07	8.99	8.74	8.38		
製品名		凝縮温度(℃)						
		30	35	38	40	45	50	
J□E-E80□□TW	蒸発温度(℃)	10	29.7	31.4	32.1	32.5	33.1	33.2
		5	29.2	30.4	30.9	31.2	31.5	31.3
		0	27.8	28.7	29.0	29.2	29.3	29.0
		-5	26.4	27.0	27.2	27.2	27.2	26.8
		-10	24.7	25.1	25.2	25.2	25.1	24.6
		-15	22.5	22.8	22.8	22.8	22.6	22.1
		-20	20.1	20.3	20.3	20.2	19.9	19.4
		-25	18.0	18.0	18.0	17.9	17.6	17.1
		-30	16.2	16.2	16.2	16.1	15.7	15.2
		-35	14.6	14.5	14.4	14.3	14.0	13.5
		-40	12.8	12.7	12.6	12.5	12.2	11.7
-45	11.8	11.7	11.6	11.5	11.1	10.7		
製品名		凝縮温度(℃)						
		30	35	38	40	45	50	
J□E-E100□□TW	蒸発温度(℃)	10	33.9	35.8	36.6	37.1	37.7	37.8
		5	33.3	34.6	35.2	35.5	35.8	35.7
		0	31.7	32.7	33.0	33.2	33.3	33.0
		-5	30.1	30.8	31.0	31.1	31.0	30.6
		-10	28.3	28.7	28.8	28.8	28.7	28.1
		-15	25.8	26.1	26.1	26.1	25.8	25.2
		-20	23.0	23.1	23.1	23.1	22.7	22.2
		-25	20.4	20.5	20.4	20.4	20.0	19.4
		-30	18.4	18.4	18.3	18.3	17.9	17.3
		-35	16.5	16.5	16.4	16.3	15.9	15.3
		-40	14.7	14.6	14.5	14.4	14.0	13.5
-45	14.0	13.9	13.8	13.7	13.3	12.7		

製品名		凝縮温度(℃)						
		30	35	38	40	45	50	
J□E-E125□□TW	蒸発温度(℃)	10	39.1	41.3	42.3	42.8	43.5	43.7
		5	38.3	39.9	40.5	40.9	41.3	41.1
		0	36.5	37.6	38.0	38.2	38.3	38.0
		-5	34.6	35.4	35.7	35.8	35.7	35.2
		-10	32.5	33.1	33.2	33.2	33.0	32.4
		-15	29.8	30.1	30.1	30.1	29.8	29.1
		-20	26.6	26.8	26.8	26.7	26.3	25.7
		-25	23.8	23.9	23.8	23.7	23.3	22.6
		-30	21.5	21.5	21.4	21.3	20.9	20.2
		-35	19.4	19.3	19.2	19.1	18.6	18.0
		-40	17.3	17.2	17.0	16.9	16.5	15.8
-45	16.6	16.4	16.3	16.1	15.7	15.0		
製品名		凝縮温度(℃)						
		30	35	38	40	45	50	
J□E-E150□□TW	蒸発温度(℃)	10	48.9	51.6	52.8	53.4	54.4	54.6
		5	48.5	50.5	51.4	51.8	52.3	52.1
		0	45.6	47.0	47.5	47.7	47.9	47.5
		-5	42.4	43.4	43.7	43.8	43.7	43.1
		-10	39.4	40.0	40.2	40.2	39.9	39.2
		-15	36.1	36.5	36.5	36.5	36.1	35.3
		-20	32.6	32.8	32.7	32.7	32.2	31.4
		-25	29.2	29.3	29.2	29.1	28.6	27.8
		-30	26.4	26.4	26.3	26.1	25.6	24.8
		-35	23.5	23.4	23.2	23.1	22.5	21.8
		-40	19.9	19.8	19.6	19.5	19.0	18.3
-45	18.5	18.3	18.1	18.0	17.4	16.7		
製品名		凝縮温度(℃)						
		30	35	38	40	45	50	
J□E-E200□□TW	蒸発温度(℃)	10	63.3	66.8	68.4	69.2	70.4	70.6
		5	62.8	65.4	66.5	67.0	67.7	67.4
		0	59.0	60.9	61.5	61.8	62.1	61.5
		-5	55.0	56.2	56.6	56.8	56.7	55.9
		-10	51.1	51.9	52.1	52.2	51.8	50.9
		-15	46.9	47.4	47.5	47.4	46.9	45.9
		-20	42.4	42.7	42.6	42.5	41.9	40.8
		-25	38.1	38.2	38.1	37.9	37.2	36.2
		-30	34.4	34.4	34.2	34.1	33.4	32.3
		-35	30.6	30.5	30.3	30.1	29.4	28.4
		-40	26.0	25.9	25.6	25.5	24.8	23.9
-45	21.0	20.9	20.7	20.6	20.0	19.3		



＜容量変化表＞ R407H JBE形・JAE形（ワイドレンジ）

条件：凝縮温度別、過冷却度：0℃、過熱度変化：3.5℃時の容量[kW]  
配管やエバポレータなどの圧力損失を0とした時のものです。

製品名		凝縮温度(℃)						
		30	35	38	40	45	50	
J□E-E65□□TW	蒸発温度(℃)	10	28.9	30.7	31.6	32.0	32.9	33.3
		5	28.4	29.8	30.4	30.7	31.3	31.5
		0	27.2	28.3	28.7	29.0	29.4	29.4
		-5	25.9	26.7	27.0	27.2	27.4	27.3
		-10	24.2	24.8	25.1	25.2	25.3	25.1
		-15	22.2	22.6	22.8	22.8	22.9	22.6
		-20	20.0	20.3	20.4	20.4	20.4	20.1
		-25	17.9	18.1	18.1	18.1	18.0	17.8
		-30	16.0	16.2	16.2	16.2	16.1	15.8
		-35	14.4	14.5	14.5	14.4	14.3	14.0
		-40	12.7	12.7	12.7	12.7	12.50	12.27
-45	10.78	10.69	10.59	10.49	10.19	9.78		
製品名		凝縮温度(℃)						
J□E-E80□□TW	蒸発温度(℃)	10	35.2	37.3	38.4	38.9	40.0	40.5
		5	34.5	36.2	37.0	37.4	38.1	38.4
		0	33.1	34.4	34.9	35.2	35.7	35.8
		-5	31.5	32.4	32.8	33.0	33.3	33.2
		-10	29.4	30.2	30.4	30.6	30.7	30.5
		-15	27.0	27.5	27.7	27.8	27.8	27.5
		-20	24.3	24.7	24.8	24.8	24.8	24.5
		-25	21.8	22.0	22.1	22.1	22.0	21.7
		-30	19.6	19.8	19.8	19.8	19.7	19.3
		-35	17.6	17.8	17.8	17.7	17.6	17.2
		-40	15.7	15.7	15.7	15.7	15.5	15.2
-45	13.5	13.4	13.3	13.1	12.8	12.2		
製品名		凝縮温度(℃)						
J□E-E100□□TW	蒸発温度(℃)	10	40.1	42.6	43.8	44.4	45.6	46.2
		5	39.3	41.2	42.1	42.6	43.4	43.7
		0	37.7	39.1	39.8	40.1	40.6	40.7
		-5	35.9	37.0	37.4	37.7	38.0	37.9
		-10	33.7	34.5	34.8	35.0	35.1	34.9
		-15	30.8	31.4	31.7	31.8	31.8	31.5
		-20	27.7	28.2	28.3	28.4	28.3	27.9
		-25	24.8	25.1	25.1	25.2	25.0	24.7
		-30	22.3	22.5	22.5	22.5	22.4	22.0
		-35	20.1	20.2	20.2	20.2	20.0	19.6
		-40	17.9	18.0	18.0	17.9	17.7	17.3
-45	15.7	15.5	15.4	15.3	14.8	14.2		

製品名		凝縮温度(℃)						
		30	35	38	40	45	50	
J□E-E125□□TW	蒸発温度(℃)	10	46.3	49.2	50.5	51.3	52.6	53.3
		5	45.3	47.5	48.5	49.0	50.0	50.3
		0	43.4	45.0	45.8	46.2	46.8	46.8
		-5	41.3	42.6	43.1	43.4	43.7	43.6
		-10	38.8	39.7	40.1	40.3	40.4	40.2
		-15	35.6	36.3	36.6	36.7	36.7	36.3
		-20	32.1	32.6	32.8	32.8	32.8	32.4
		-25	28.8	29.1	29.2	29.3	29.1	28.7
		-30	26.0	26.3	26.3	26.3	26.1	25.7
		-35	23.5	23.7	23.7	23.6	23.4	23.0
		-40	21.1	21.2	21.2	21.1	20.9	20.4
-45	18.6	18.5	18.3	18.1	17.6	16.9		
製品名		凝縮温度(℃)						
J□E-E150□□TW	蒸発温度(℃)	10	57.9	61.5	63.1	64.1	65.8	66.7
		5	57.4	60.1	61.4	62.1	63.3	63.7
		0	54.3	56.3	57.2	57.7	58.5	58.6
		-5	50.7	52.2	52.8	53.2	53.6	53.5
		-10	46.9	48.0	48.5	48.7	48.9	48.6
		-15	43.1	43.9	44.2	44.4	44.4	44.0
		-20	39.3	39.9	40.1	40.2	40.1	39.6
		-25	35.5	35.9	36.0	36.0	35.9	35.3
		-30	31.9	32.2	32.3	32.2	32.0	31.5
		-35	28.3	28.5	28.5	28.5	28.2	27.6
		-40	24.4	24.5	24.5	24.4	24.2	23.6
-45	23.1	22.9	22.7	22.5	21.8	20.9		
製品名		凝縮温度(℃)						
J□E-E200□□TW	蒸発温度(℃)	10	74.9	79.5	81.7	82.9	85.2	86.3
		5	74.3	77.9	79.5	80.4	82.0	82.5
		0	70.3	72.9	74.1	74.7	75.7	75.8
		-5	65.6	67.6	68.5	68.9	69.5	69.3
		-10	60.8	62.3	62.9	63.2	63.4	63.1
		-15	56.0	57.1	57.5	57.6	57.7	57.1
		-20	51.2	52.0	52.2	52.3	52.2	51.5
		-25	46.2	46.8	46.9	47.0	46.7	46.0
		-30	41.6	42.0	42.1	42.0	41.7	41.0
		-35	36.9	37.2	37.2	37.1	36.8	36.1
		-40	31.9	32.0	32.0	31.9	31.6	30.9
-45	24.9	25.1	25.0	25.0	24.7	24.2		

膨  
張  
弁